

**WE DELIVER ALL OVER
THE WORLD**



GGM GASTRO INTERNATIONAL GMBH

Weinerpark 16
48607 Ochtrup Germany

GGM GASTRO (QINGDAO) INTERNATIONAL CO. LTD

C3, Zhongyi 1688 Creative Industry Park,
Licang District, Qingdao City P.R. China

Tel. +86-532-80922137
Email: china@gmgastro.com
Website: www.gmgastro.com

@gmgastro



Product designs and specifications in this catalogue may be subject to change without notice

ggmgastro

Catalog 23/24



**EUROPE'S LARGEST CATERING
SUPPLIES RETAILER**

OUR HISTORY

For more than 15 years, we have been supplying professional equipment to the catering industry. We are a German company that shines through constant progress and is now even the European market leader for catering equipment and kitchen accessories. What are the latest catering trends? What innovations are there? How can we make the work of the restaurateur easier? With all these questions in mind, we are on the lookout worldwide for the latest and best products for the industry.

Revolution in the kitchen? No problem with us! Both the German and the international market are supplied with everything that makes the restaurateur's heart beat faster. We offer everything from tableware to dishwashers to combi-steamers with Android control panels! We also offer our customers advice on tailor-made catering solutions and a technical on-site service, as the individual needs of our customers are close to our hearts.

With our network and direct contacts to manufacturers from Germany, Italy and overseas, we can offer you our products with a lowest price guarantee. Together with partners, customers and the team of almost 500 employees, GGM Gastro achieves new successes every year. Founders are passionately supported in kitchen planning, custom programmes for internal data management are developed and major marketing campaigns are planned - all done in-house!

We are continuously working on optimizing the range and service we offer and reaching more and more restaurateurs. At currently 20 international locations, GGM Gastro can be reached in person by customers and is there to help and advise them.

So what are you waiting for? Take advantage of our experience and share in our successful future!



 5 million products
immediately available

 Shopping at the
lowest prices

 More than 20.000
different articles

 Over 1.000.000
customers

 Save & certified

 120.000 m²
storage space



GLOBALLY NETWORKED AND EVERYWHERE ON SITE FOR YOU.

Our locations at a glance

Visit our Showrooms



For you on site

We are more than just an online store: For some time now, we have been tapping international markets not only in e-commerce, but also through physical locations around the world. Many new locations are in the planning stage and by no means all of them are listed on this overview. Our goal is to enable customers and partners to get a picture of products and the company GGM Gastro directly on site.

14

Countries

20

Locations

500

Employees

180

Shipping Countries

Locations Germany



 **Ochtrup**
Headquarter

 Weinerpark 16
48607 Ochtrup
 info@ggm-gastro.com
 +49 (0) 2553 722 01 00



 **Hamburg**



 Wendenstraße 8-12
20097 Hamburg

 **Munich**



 Am Fuchsbogen 7
82256 Fürstenfeldbruck

 **Berlin**



 Spandauer Straße 112
14612 Falkensee

 **Frankfurt**



 Danziger Straße 3
65428 Rüsselsheim am Main

 Austria



Wien

📍 Laxenburgerstrasse 196
2331 Vösendorf

 The Netherlands



Amsterdam

📍 Duivendrecht, Spaklerweg 87
1114 AE Amsterdam

 Belgium



Mechelen

📍 Blarenberglaan 6
2800 Mechelen

 Poland



Krakau

📍 Wielicka 250
32-020 Kraków

 Sweden



Göteborg

📍 Gamla Flygplatsvägen 28C
423 37 Torslanda

 Sweden



Göteborg

📍 Amalia Jönssons gata 21
421 31 Västra Frölunda

 Denmark



Køge

📍 Tangmosevej 102
4600 Køge

 Spain



Barcelona

📍 Avinguda Meridiana 525
08016 Barcelona

 Spain



Málaga

📍 C. Navarro Ledesma 192,
29010 Málaga

 Bulgaria



Plovdiv

📍 Osvozhdenie Blvd. 3
4023 Plovdiv

 Greece



Athen

📍 Rodou 208
104 43 Athina

 Rumania



Bukarest

📍 Bulevardul Pipera 200 A
Voluntari 077190 Ilfov

 Turkey



Istanbul

📍 Merkez Mahallesi
No:5 Kat 2 18-19-20
34406 Kâğıthane

 China



Qingdao

📍 C3, Zhongyi 1688
Qingdao City, Shandong

 India



Vadodara

📍 Office No: 915, Signet Hub
Near Akshar Chowk
Vadodara - 390012

OUR BEST SELLERS FOR YOUR INDIVIDUAL REQUEST



Economically and psychologically speaking, satisfaction comes from the actual performance being greater than the expected performance. That is to say, when the expectations of the customer are exceeded by what is supplied. At GGM Gastro international, we work constantly towards high level of customer satisfaction.

Our aim is always to exceed your expectations to our satisfaction. Sustainability is also important to us. Every year we visit trade fairs around the world to ensure what we are always offering the most efficient and most environmentally-friendly devices.



With over 1.000.000 satisfied customers worldwide and more than 6.200 positive Ebay ratings we become one of the best catering equipment providers on the market.

Take a look by yourself and become one of our satisfied customers!





SELF PRODUCED PHOTOS AND DESIGN

One of our 13 departments deals almost exclusively with marketing for our company GGM Gastro international.

Here the latest trends, techniques and innovations are observed and implemented to your benefit. Every flyer, every brochure, every image and every newsletter: we design everything in house. This means that we are in a position to advertise our newest and best products right from the market stage.

All items, from fridges and cutlery sets, can be photographed in our in-house photography studio. In our on-line shop you can inspect every product in detail and select the perfect one for you.

And ever increasing selection in our product range is modelled in 3D. This enables us to offer you a 360° overview of a product.





GERMAN STANDARD - WE PRODUCE ACCORDING TO YOUR WISHES!

Every customer, every company and every operation is individual. In today's catering industry, perfectly-tuned equipment is essential to success. At GGM Gastro international we strive to offer you the very best possible results. We produce exclusively according to the German standard, so that each product corresponds to the best quality. Thanks to our large range, we can achieve this perfectly. More than 30 employees are available to offer expert advice so that you only buy what you really need. And always the best possible price.

Whether a cold store, cooking utensils or kitchen units. We offer the perfect solution to your requirements.

We are also certified store and awarded from TÜV and ISO.





OUR PRODUCT CATEGORIES



Business Type



Cooking Appliances



Ventilation



Pizza & Grill



Stainless Steel Furniture



Refrigeration



Combi Steamer



Kitchen Appliances



Heat retention



Rinsing & Cleaning



Retail Refrigeration



Café & Ice Cream



Kitchenware



Table Setting

Alongside our excellent advice and premium quality, what sets us apart is our variety of catering equipment. Whatever you require, we can deliver at the best price!

So you have the opportunity to buy everything from one supplier. This means better conditions, quicker delivery and perfectly adapted products to meet your needs.

Choose from over 14.300 items in our online shop. Our employees add new items almost daily to ensure that we are constantly up to date.

This means that we are always able to provide you with the very latest technology and innovative design.





OUR LOGISTICS SERVICE FOR FAST DELIVERY



To ensure absolute fulfilment at all times, we have over 35.000 m² of warehouse space, spread across two modern halls. Thanks to the excellent motorway connections in the ochtrup industrial area, we can supply most of our range within 2 to 5 working days. We work closely with long-standing partners in logistics and

shipping to ensure that our goods are always delivered reliably and punctually. In 2018 we have built a third hall. This expanding our warehouse capacity by more than 20.000 m² to around 55.000 m². This enable us to supply our goods even more efficiently and reliably.



STRONG IN THE FIELD, STRONG IN THE KITCHEN

Together with our soccer partners we have great challenges and projects. Check out our YouTube channel and see for yourself!



Marco Reus

Jude Bellingham

Mats Hummels



Kenan Karaman

Look at our partners
on youtube



We are looking forward to a nice partnership in the future
and wish them all the best for the following seasons!



Borussia Dortmund



FC Schalke 04

Contents

PROFESSIONAL REFRIGERATION

P018~057

- 018-021 ■ Refrigerated cabinet
- 022-023 ■ Refrigerated table
- 023-023 ■ Premium preparation table
- 024-025 ■ Refrigerated pizza table
- 026-026 ■ Deep freeze drawer cabinet
- 026-028 ■ Refrigerated saladette
- 029-029 ■ Refrigerated cool display
- 030-031 ■ Upright chiller/freezer
- 032-032 ■ Blast chiller/freezer
- 032-032 ■ Mini bar - ice freezer
- 032-033 ■ Mini fridge
- 033-034 ■ Backbar cooler
- 035-036 ■ Beverage cooler
- 036-036 ■ Bottle refrigerator
- 037-037 ■ Multideck
- 037-037 ■ Refrigerated display cabinets for meat
- 038-038 ■ Wall cabinet
- 038-038 ■ Refrigerated island
- 038-038 ■ Refrigerated shelves
- 039-040 ■ Panorama display case
- 040-040 ■ Sushi showcase
- 041-041 ■ Table display case with self-service
- 041-042 ■ Table refrigerated display case
- 043-044 ■ Cake showcase
- 045-047 ■ Ice maker
- 047-049 ■ Wine cooler
- 050-050 ■ Top curved sliding lid chest freezer
- 050-050 ■ Top flat sliding lid chest freezer
- 051-051 ■ Solid lid chest freezer
- 052-052 ■ Ice cream machine
- 053-053 ■ Table ice showcase
- 053-053 ■ Ice-cream cart
- 054-054 ■ Ice-cream showcase
- 055-055 ■ Beer cooler with tap
- 055-055 ■ Slush machine
- 056-057 ■ Juice dispenser
- 057-057 ■ Beer tower
- 057-057 ■ Milk refrigerator with cup warmer

COOKING EQUIPMENT

P060~099

- 060-060 ■ Electric deep fryer
- 060-061 ■ Electric griddle
- 061-062 ■ Gas stove
- 062-062 ■ Electric stove
- 063-063 ■ Chip heating
- 063-063 ■ Neutral element-with drawer
- 064-064 ■ Gas lava rock grill
- 064-064 ■ Bain marie
- 065-065 ■ Substructure
- 066-066 ■ Electric griddle
- 066-067 ■ Industrial toaster
- 067-068 ■ 9 slice toaster
- 068-069 ■ Waffle maker
- 069-069 ■ Cone maker
- 070-071 ■ Salamander
- 071-071 ■ Toaster
- 072-075 ■ Fryer
- 075-075 ■ Automatic donut machine
- 075-075 ■ Tree striezel machine
- 076-076 ■ Takoyaki machine
- 076-076 ■ Egg tart machine
- 077-077 ■ Pasta cooker
- 077-078 ■ Induction cooker
- 078-078 ■ China wok for open kitchen
- 078-078 ■ Gas cooker
- 079-079 ■ Microwave oven
- 080-080 ■ Pizza oven
- 081-081 ■ Steam oven
- 081-081 ■ Speed oven
- 082-082 ■ Hot air circulating electric oven
- 082-082 ■ Slice toaster
- 082-082 ■ Egg boiler
- 082-082 ■ Rice cooker
- 083-083 ■ Crepes device
- 083-083 ■ Sous vide
- 083-083 ■ Sous vide cooker
- 084-084 ■ Bain marie
- 084-084 ■ Bain marie thermal trolley
- 084-084 ■ Electric hamburger machines
- 085-085 ■ Hot dog grill
- 085-085 ■ Hot dog maker
- 085-085 ■ Hot dog display case
- 086-086 ■ Cotton candy machine
- 086-086 ■ Popcorn machine
- 086-086 ■ Trolley for popcorn machine
- 087-087 ■ Chocolate fountain
- 087-087 ■ Hot chocolate dispenser
- 087-087 ■ Chocolate melting machine
- 087-087 ■ Chip warmer
- 088-088 ■ Cheese warmer
- 088-088 ■ Stainless steel sauce dispenser
- 088-088 ■ Sausage warmer
- 088-088 ■ Thermal bridge
- 089-089 ■ Fries warmers
- 089-089 ■ Heat retaining plate
- 090-090 ■ Cooling plate for gn pan
- 090-090 ■ Stainless steel food warmer
- 090-090 ■ Heat lamp
- 091-091 ■ Heated display case
- 091-091 ■ Food steam showcase
- 091-091 ■ Plate warmer
- 092-092 ■ Cup warmer
- 092-092 ■ Food dehydrator
- 093-093 ■ Banquet trolley
- 093-093 ■ Top bain marie with glass lid
- 093-093 ■ Bain marie hotpot
- 094-095 ■ Chafing dish
- 095-095 ■ Soup warmer
- 096-096 ■ Soup kettle
- 096-096 ■ Coffee percolator
- 096-096 ■ Water boiler
- 097-097 ■ Coffee machine
- 098-098 ■ Coffee station
- 098-098 ■ Hot drinks dispenser
- 098-098 ■ Warming plate
- 099-099 ■ Glass icer with led lighting
- 099-099 ■ Smoker house

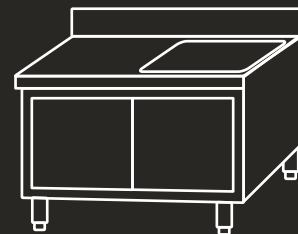
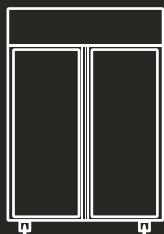

FOOD PROCESSING EQUIPMENT

NEUTRAL PRODUCT

P102~127

- | | | | |
|---------|----------------------------|---------|---|
| 102-103 | ■ Food slicer | 118-118 | ■ Churro machine |
| 103-103 | ■ Vegetable slicer | 118-118 | ■ Manual donut tool |
| 104-104 | ■ Vegetable cutter | 118-119 | ■ Hopper |
| 104-104 | ■ Potato peeler | 119-119 | ■ Filling machine |
| 104-104 | ■ Potato spiral cutter | 120-120 | ■ Electric oil press |
| 105-105 | ■ Manual potato cutter | 120-120 | ■ Juice extractor |
| 105-105 | ■ Manual cutting machine | 121-121 | ■ Food mixer |
| 105-105 | ■ Praline cutter | 121-121 | ■ Orange squeezer |
| 106-106 | ■ Tomato slicer | 122-122 | ■ Vacuum machine |
| 106-106 | ■ Kebab slicer | 122-122 | ■ Mobile glass washer |
| 106-106 | ■ Horizontal cutter | 123-123 | ■ Dish washer |
| 107-107 | ■ Curry sausage slicer | 123-123 | ■ Honey extractor |
| 107-107 | ■ Electric meat tenderiser | 123-123 | ■ Sesame peanut butter machine |
| 108-108 | ■ Mincing machine | 124-124 | ■ Poultry plucker |
| 109-109 | ■ Meat mixer | 124-124 | ■ Poultry plucker and scalding |
| 109-109 | ■ Manual meat tenderizer | 124-124 | ■ Scalding kettle poultry |
| 110-111 | ■ Sausage stuffer | 125-125 | ■ Hand dryer |
| 112-112 | ■ Bone saw | 125-125 | ■ Shoe polisher |
| 112-112 | ■ Cake smoothing machine | 125-125 | ■ Can opener |
| 112-112 | ■ Hamburger machine | 126-126 | ■ Juice extractor manually |
| 113-114 | ■ Mixer | 126-126 | ■ Knife sharpener |
| 115-115 | ■ Dough kneading machine | 126-126 | ■ Manual stainless steel
sausage clipper |
| 115-115 | ■ Bakery dough sheeter | 127-127 | ■ Table ice crusher |
| 115-115 | ■ Horizontal cutter stand | 127-127 | ■ Food trailer |
| 116-116 | ■ Hand blender | | |
| 117-117 | ■ Spindle mixer | | |

P130~169

- | | |
|---------|---------------------------------------|
| 130-132 | ■ Work table |
| 132-132 | ■ Top shelf |
| 133-133 | ■ Heating light |
| 133-133 | ■ Drawer block - base module |
| 134-134 | ■ Rubbish bin - substructure module |
| 134-134 | ■ Stainless steel chopping block |
| 134-134 | ■ Meat table |
| 135-136 | ■ Sink unit with floor base |
| 137-137 | ■ Dishwasher sink |
| 138-138 | ■ Hand wash sink |
| 138-140 | ■ Stainless steel sink cabinet |
| 140-141 | ■ Dishwasher cabinet |
| 142-144 | ■ Stainless steel work cabinet |
| 145-145 | ■ Beverage dispenser base cabinet |
| 145-145 | ■ Substructure |
| 146-146 | ■ Rubbish bin with roll container |
| 146-146 | ■ Flour trolley |
| 147-147 | ■ Litter bin with lift lid |
| 147-147 | ■ Drawer cabinet |
| 148-148 | ■ Corner cabinet |
| 148-148 | ■ Corner work table |
| 148-148 | ■ Tableware cabinet |
| 149-150 | ■ Wall cabinet |
| 150-151 | ■ Self assembly |
| 152-152 | ■ Stainless steel cash desk |
| 152-152 | ■ Wall-hanging cabinet |
| 152-152 | ■ Exhaust hood no blower with filter |
| 153-153 | ■ Flame protection filter |
| 153-153 | ■ Food shelf |
| 153-153 | ■ Wall shelves |
| 154-154 | ■ Stainless steel shelf |
| 154-158 | ■ Trolley |
| 159-159 | ■ Stainless steel foldable work table |
| 159-159 | ■ Stainless steel cutlery tray |
| 159-160 | ■ Wall shelf spice shelf |
| 161-161 | ■ Cup dispenser |
| 161-161 | ■ S/s pet grooming bathtub |
| 161-161 | ■ Coffee grounds drawer |
| 162-162 | ■ Insect killer |
| 162-165 | ■ Stainless steel gn container |
| 165-165 | ■ Milk jug with lid |
| 166-166 | ■ Aluminum pizza peel |
| 167-169 | ■ Sink tap |

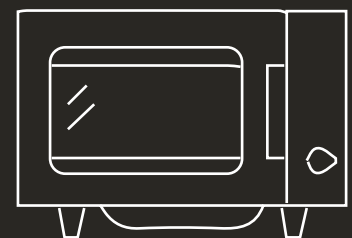
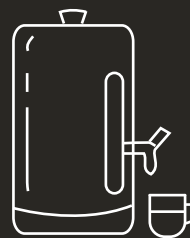
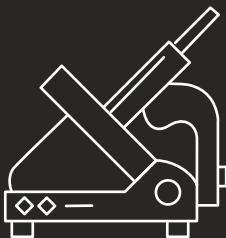

PROFESSIONAL REFRIGERATION





- Refrigerated cabinet
- Refrigerated table
- Premium preparation table
- Refrigerated pizza table
- Deep freeze drawer cabinet
- Refrigerated saladette
- Refrigerated cool display
- Upright chiller/freezer
- Blast chiller/freezer
- Mini bar - ice freezer
- Mini fridge
- Backbar cooler
- Beverage cooler
- Bottle refrigerator
- Multideck
- Refrigerated display cabinets for meat
- Wall cabinet
- Refrigerated island
- Refrigerated shelves
- Panorama display case
- Sushi showcase
- Table display case with self-service
- Table refrigerated display case
- Cake showcase
- Ice maker
- Wine cooler
- Top curved sliding lid chest freezer
- Top flat sliding lid chest freezer
- Solid lid chest freezer
- Ice cream machine
- Table ice showcase
- Ice-cream cart
- Ice-cream showcase
- Beer cooler with tap
- Slush machine
- Juice dispenser
- Beer tower
- Milk refrigerator with cup warmer



PROFESSIONAL REFRIGERATION

REFRIGERATED CABINET

- European fashionable style upright cabinet chiller/freezer
- Impressive performance with low power consumption (environmentally friendly)
- Exceptionally efficient cooling motor
- Changeable door hinge
- Magnetic sealing strip keeps the cold air inside
- Inner box curved edges for easy cleaning
- Reversible self-closing door
- Adjustable feet or caster wheels
- Automatic defrost
- With lock and key
- LED light
- Three layers of coated shelves as standard



KKSJ650ND
TKKSJ650ND



KKSJ650GND
TKKSJ650GND

Model	Product Dim (W/D/H mm)	Net Capacity (L)	Voltage /Frequency(V/Hz)	Power(W)	Cooling System	Temp(°C)	Shelves No.	Compressor	Digital thermostat	Refrigerant	40 HQ Container Loading
KKSJ650ND	740x830x2010	440	220-240/50	305	Ventilated	-2~8	3	Donper	Dixell	R290	41
TKKSJ650ND	740x830x2010	440	220-240/50	591	Ventilated	-18~-22	3	Cubigel	Dixell	R290	41
KKSJ650GND	740x830x2010	440	220-240/50	305	Ventilated	-2~8	3	Donper	Dixell	R290	41
TKKSJ650GND	740x830x2010	440	220-240/50	591	Ventilated	-15~-18	3	Cubigel	Dixell	R290	41



KKSJ1400ND
TKKSJ1400ND



KKSJ1400GND
TKKSJ1400GND

- European fashionable style upright cabinet chiller/freezer
- Impressive performance with low power consumption (environmentally friendly)
- Exceptionally efficient cooling motor
- Changeable door hinge
- Magnetic sealing strip keeps the cold air inside
- Inner box curved edges for easy cleaning
- Reversible self-closing door
- Adjustable feet or caster wheels
- Automatic defrost
- With lock and key
- LED light
- Two full size doors, large storage capacity

Model	Product Dim (W/D/H mm)	Net Capacity (L)	Voltage /Frequency(V/Hz)	Power(W)	Cooling System	Temp(°C)	Shelves No.	Compressor	Digital thermostat	Refrigerant	40 HQ Container Loading
KKSJ1400ND	1480x830x2010	1035	220-240/50	500	Ventilated	-2~8	6	ZEL	Dixell	R290	15
TKKSJ1400ND	1480x830x2010	1035	220-240/50	740	Ventilated	-18~-22	6	Cubigel	Dixell	R290	15
KKSJ1400GND	1480x830x2010	1035	220-240/50	500	Ventilated	-2~8	6	ZEL	Dixell	R290	15
TKKSJ1400GND	1480x830x2010	1035	220-240/50	740	Ventilated	-15~-18	6	Cubigel	Dixell	R290	15

REFRIGERATED CABINET

- European fashionable style upright cabinet chiller/freezer
- Impressive performance with low power consumption (environmentally friendly)
- Exceptionally efficient cooling motor
- Magnetic sealing strip keeps the cold air inside
- Inner box curved edges for easy cleaning
- Reversible self-closing door
- Adjustable feet or caster wheels
- With lock and key
- LED light
- Automatic defrost



KS600ND
TS600ND



KS1200ND
TS1200ND

Model	Product Dim (W/D/H mm)	Net Capacity (L)	Voltage /Frequency(V/Hz)	Power(W)	Cooling System	Temp(°C)	Shelves No.	Compressor	Digital thermostat	Refrigerant	40 HQ Container Loading
KS600ND	740x730x2010	352	220-240/50	305	Ventilated	-2~8	3	ZEL	Dixell	R290	45
TS600ND	740x730x2010	352	220-240/50	520	Ventilated	-10~-22	3	Cubigel	Dixell	R290	45
KS1200ND	1480x730x2010	864	220-240/50	508	Ventilated	-2~8	6	ZEL	Dixell	R290	22
TS1200ND	1480x730x2010	864	220-240/50	815	Ventilated	-10~-22	6	Secop	Dixell	R290	22

- European fashionable style upright cabinet chiller/freezer
- Impressive performance with low power consumption (environmentally friendly)
- Exceptionally efficient cooling motor
- Magnetic sealing strip keeps the cold air inside
- Inner box curved edges for easy cleaning
- Reversible self-closing door
- Adjustable feet or caster wheels
- With lock and key
- LED light
- Automatic defrost
- Glass door



KS600GND
TS600GND



KS1200GND
TS1200GND

Model	Product Dim (W/D/H mm)	Net Capacity (L)	Voltage /Frequency(V/Hz)	Power(W)	Cooling System	Temp(°C)	Shelves No.	Compressor	Digital thermostat	Refrigerant	40 HQ Container Loading
KS600GND	740x730x2010	352	220-240/50	305	Ventilated	-2~8	3	ZEL	Dixell	R290	45
TS600GND	740x730x2010	352	220-240/50	520	Ventilated	-12~-15	3	Secop	Dixell	R290	45
KS1200GND	1480x730x2010	864	220-240/50	508	Ventilated	-2~8	6	ZEL	Dixell	R290	22
TS1200GND	1480x730x2010	864	220-240/50	815	Ventilated	-12~-15	6	Secop	Dixell	R290	22

PROFESSIONAL REFRIGERATION

REFRIGERATED CABINET



- Independent refrigeration unit, can be directly replaced
- Impressive performance with low power consumption (environmentally friendly)
- Exceptionally efficient cooling motor
- Self evaporation of defrosting water without the need for drainage pipes or external evaporation bags
- Heat pump defrosting, safer than electric heating tube defrosting
- Touch screen digital display electronic control
- TPE door seal, does not deform and harden at low temperature compared to traditional PVC material
- Alarm prompt when the door is not closed properly



Model	Product Dim (W/D/H mm)	Net Capacity (L)	Voltage /Frequency(V/Hz)	Power(W)	Cooling System	Temp(°C)	Shelves No.	Compressor	Digital thermostat	Refrigerant	40 HQ Container Loading
KSH700	740x830x1985	476	220-240/50	240	Ventilated	0~8	3	Cubigel	Taige	R290	42
TSH700	740x830x1985	476	220-240/50	347	Ventilated	-18~-22	3	Cubigel	Taige	R290	42
KSH1400	1480x830x1985	916	220-240/50	340	Ventilated	0~8	6	Cubigel	Taige	R290	15
TSH1400	1480x830x1985	916	220-240/50	503	Ventilated	-18~-22	6	Cubigel	Taige	R290	15



Model	Product Dim (W/D/H mm)	Net Capacity (L)	Voltage /Frequency(V/Hz)	Power(W)	Cooling System	Temp(°C)	Shelves No.	Compressor	Digital thermostat	Refrigerant	40 HQ Container Loading
KSH600	680x710x1985	375	220-240/50	240	Ventilated	0~8	3	Cubigel	Taige	R290	47
TSH600	680x710x1985	375	220-240/50	347	Ventilated	-18~-22	3	Cubigel	Taige	R290	47
KSH1200	1340x710x1985	770	220-240/50	340	Ventilated	0~8	6	Cubigel	Taige	R290	23
TSH1200	1340x710x1985	770	220-240/50	503	Ventilated	-18~-22	6	Cubigel	Taige	R290	23

REFRIGERATED CABINET

- European fashionable style upright cabinet chiller/freezer
- Impressive performance with low power consumption (environmentally friendly)
- Exceptionally efficient cooling motor
- Magnetic sealing strip keeps the cold air inside
- Inner box curved edges for easy cleaning
- Reversible self-closing door
- Adjustable feet or caster wheels
- Automatic defrost
- With lock and key
- LED light
- Digital thermostat
- Changeable door hinge



KG400T1ND
TG400T1ND

Model	Product Dim (W/D/H mm)	Net Capacity (L)	Voltage /Frequency(V/Hz)	Power(W)	Cooling System	Temp(°C)	Shelves No.	Compressor	Digital thermostat	Refrigerant	40 HQ Container Loading
KG400T1ND	680x710x2000	328	220-240/50	175	Static with fan	-2~8	3	Cubigel	Dixell	R290	48
TG400T1ND	680x710x2000	328	220-240/50	420	Static with fan	-15~-20	3	Cubigel	Dixell	R290	48

- European fashionable style upright cabinet chiller/freezer
- Impressive performance with low power consumption (environmentally friendly)
- Exceptionally efficient cooling motor
- Magnetic sealing strip keeps the cold air inside.
- Inner box curved edges for easy cleaning
- Reversible self-closing door
- Compatible for 7 pans with dimension 400mmx600mm
- Adjustable feet or caster wheels
- Automatic defrost
- With lock and key
- LED light



KFG530T1ND
TFG530T1ND

Model	Product Dim (W/D/H mm)	Net Capacity (L)	Voltage /Frequency(V/Hz)	Power(W)	Cooling System	Temp(°C)	Pans No.	Compressor	Digital thermostat	Refrigerant	40 HQ Container Loading
KFG530T1ND	680x810x2000	396	220-240/50	175	Static with fan	-2~8	7	Cubigel	Dixell	R290	42
TFG530T1ND	680x810x2000	396	220-240/50	420	Static with fan	-15~-20	7	Cubigel	Dixell	R290	42

- European fashionable style upright cabinet chiller/freezer
- Impressive performance with low power consumption (environmentally friendly)
- Exceptionally efficient cooling motor
- Magnetic sealing strip keeps the cold air inside.
- Inner box curved edges for easy cleaning
- Reversible self-closing door
- Four wheels with parking brake
- Automatic defrost
- With lock and key
- LED light



BKG800ND
BTKG800ND



BTKG800GEN

Model	Product Dim (W/D/H mm)	Net Capacity (L)	Voltage /Frequency(V/Hz)	Power(W)	Cooling System	Temp(°C)	Shelves No.	Compressor	Digital thermostat	Refrigerant	40 HQ Container Loading
BKG800ND	740x990x2000	612	220-240/50	295	Ventilated	-2~8	2xGN 400x600mm	Cubigel	Dixell	R290	33
BTKG800ND	740x990x2000	612	220-240/50	520	Ventilated	-18~-22	2xGN 400x600mm	Cubigel	Dixell	R290	33
BTKG800GEN	740x990x2000	612	220-240/50	520	Ventilated	-15~-18	10	Cubigel	Dixell	R290	33

PROFESSIONAL REFRIGERATION

REFRIGERATED TABLE



KTS147ND
GTS147ND



KTS187ND
GTS187ND



KTS227ND
GTS227ND

- Revisable self-closing door
- Full length stainless steel handle
- Adjustable feet or caster wheels
- Automatic defrost
- Optional with GN1/3,GN2/3,GN1/2 Drawers

Model	Product Dim (W/D/H mm)	Net capacity (L)	Voltage /Frequency(V/Hz)	Power (W)	Cooling system	Temp(°C)	Shelves No.	Compressor	Digital thermostat	Refrigerant	40 HQ Container loading
KTS147ND	1360x700x870	196	220-240/50	275	Ventilated	-2~8	2	ZEL	dixell	R600a	48
GTS147ND	1360x700x870	196	220-240/50	675	Ventilated	-10~-22	2	Secop	dixell	R290	48
KTS187ND	1795x700x870	294	220-240/50	275	Ventilated	-2~8	3	ZEL	dixell	R600a	38
GTS187ND	1795x700x870	294	220-240/50	675	Ventilated	-10~-22	3	Secop	dixell	R290	38
KTS227ND	2230x700x870	421	220-240/50	398	Ventilated	-2~8	4	ZEL	dixell	R290	32
GTS227ND	2230x700x870	421	220-240/50	675	Ventilated	-10~-22	4	Secop	dixell	R290	32



KTS147AND



KTS187AND



KTS227AND

- Revisable self-closing door
- Impressive performance with low power consumption (environmentally friendly)
- Full length stainless steel handle
- Adjustable feet or caster wheels
- Automatic defrost
- Optional with GN1/3,GN2/3,GN1/2 Drawers
- With upstand

Model	Product Dim (W/D/H mm)	Net capacity (L)	Voltage /Frequency(V/Hz)	Power (W)	Cooling system	Temp(°C)	Shelves No.	Compressor	Digital thermostat	Refrigerant	40 HQ Container loading
KTS147AND	1360x700x970	196	220-240/50	275	Ventilated	-2~8	2	ZEL	dixell	R600a	48
KTS187AND	1795x700x970	294	220-240/50	275	Ventilated	-2~8	3	ZEL	dixell	R600a	38
KTS227AND	2230x700x970	421	220-240/50	398	Ventilated	-2~8	4	ZEL	dixell	R290	32

- European fashionable style refrigerated table
- Impressive performance with low power consumption (environmentally friendly)
- Revisable self-closing door
- Full length stainless steel handle
- Replaceable magnetic door seal
- Adjustable feet or caster wheels
- Automatic defrost
- Easy to clean



BKJ158ND



BKJ208ND

Model	Product Dim (W/D/H mm)	Net capacity (L)	Voltage /Frequency(V/Hz)	Power (W)	Cooling system	Temp(°C)	Shelves No.	Compressor	Digital thermostat	Refrigerant	40 HQ Container loading
BKJ158ND	1510x800x850	294	220-240/50	260	Ventilated	-2~8	2	Donper	Dixell	R290	30
BKJ208ND	2020x800x850	456	220-240/50	260	Ventilated	-2~8	3	Donper	Dixell	R290	28

REFRIGERATED TABLE



- Independent refrigeration unit, can be directly replaced
- Impressive performance with low power consumption (environmentally friendly)
- Self evaporation of defrosting water without the need for drainage pipes or external evaporation bags
- Heat pump defrosting, safer than electric heating tube defrosting
- Touch screen digital display electronic control
- TPE door seal, does not deform and harden at low temperature compared to traditional PVC material
- Alarm prompt when the door is not closed properly



KSH136



KSH177



KSH223

Model	Product Dim (W/D/H mm)	Net capacity (L)	Voltage /Frequency(V/Hz)	Power (W)	Cooling system	Temp(°C)	Shelves No.	Compressor	Digital thermostat	Refrigerant	40 HQ Container loading
KSH136	1360x700x950	282	220-240/50	240	Ventilated	0 ~ 8	2	Cubigel	Taige	R290	48
KSH177	1795x700x950	417	220-240/50	240	Ventilated	0 ~ 8	3	Cubigel	Taige	R290	38
KSH223	2230x700x950	553	220-240/50	240	Ventilated	0 ~ 8	4	Cubigel	Taige	R290	30

PREMIUM PREPARATION TABLE



ZBG157ND
ZBG158ND



ZBG207ND
ZBG208ND



- European fashionable style preparation table
- Revisable self-closing door
- Full length stainless steel handle
- Replaceable magnetic door seal
- Adjustable feet or caster wheels
- Automatic defrost
- Easy to clean
- Compatible for 7xGN1/3 pans on Prep-top for ZBG157ND, 8xGN1/3 pans for ZBG158ND&ZBG207ND, and 10xGN1/3 pans for ZBG208ND

Model	Product Dim (W/D/H mm)	Net Capacity (L)	Voltage /Frequency(V/Hz)	Power(W)	Cooling System	Temp(°C)	Shelves No.	Compressor	Digital thermostat	Refrigerant	40 HQ Container Loading
ZBG157ND	1360x700x1085	282	220-240/50	200	Ventilated	2~8	2	Donper	Dixell	R600a	48
ZBG158ND	1510x800x1085	390	220-240/50	260	Ventilated	2~8	2	Donper	Dixell	R600a	30
ZBG207ND	1795x700x1085	417	220-240/50	200	Ventilated	2~8	3	Donper	Dixell	R290	38
ZBG208ND	2020x800x1085	580	220-240/50	260	Ventilated	2~8	3	Donper	Dixell	R290	28

PROFESSIONAL REFRIGERATION

REFRIGERATED PIZZA TABLE



POS158SG



POS158SSG



POS208SG



POS208SSG

- Reversible self-closing door
- Impressive performance with low power consumption (environmentally friendly)
- Exceptionally efficient cooling motor
- Full length stainless steel handle
- Adjustable feet or caster wheels
- Automatic defrost
- Working surface with upstand made of black galaxy granite
- POS158SSG & POS208SSG with 7 neutral drawers



Model	Product Dim (W/D/H mm)	Net Capacity (L)	Voltage /Frequency(V/Hz)	Power(W)	Cooling System	Temp(°C)	Shelves No.	Compressor	Digital thermostat	Refrigerant	40 HQ Container Loading
POS158SG	1500x800x1000	294	220-240/50	275	Ventilated	-2~8	2	ZEL	EVCO	R600a	30
POS158SSG	1500x800x1000	132	220-240/50	275	Ventilated	-2~8	1	ZEL	EVCO	R600a	30
POS208SG	2025x800x1000	456	220-240/50	398	Ventilated	-2~8	3	Embraco	EVCO	R290	28
POS208SSG	2025x800x1000	294	220-240/50	275	Ventilated	-2~8	2	ZEL	EVCO	R600a	28

- Reversible self-closing door
- Impressive performance with low power consumption (environmentally friendly)
- Exceptionally efficient cooling motor
- Working surface with upstand made of granite
- POS158SND & POS208SND with 7 neutral drawers
- Full length stainless steel handle
- Adjustable feet or caster wheels
- Automatic defrost



POS158ND



POS158SND



POS208ND



POS208SND

Model	Product Dim (W/D/H mm)	Net Capacity (L)	Voltage /Frequency(V/Hz)	Power(W)	Cooling System	Temp(°C)	Shelves No.	Compressor	Digital thermostat	Refrigerant	40 HQ Container Loading
POS158ND	1510x800x1000	294	220-240/50	275	Ventilated	-2~8	2	ZEL	Dixell	R600a	30
POS158SND	1515x800x1000	132	220-240/50	275	Ventilated	-2~8	1	ZEL	Dixell	R600a	30
POS208ND	2020x800x1000	456	220-240/50	398	Ventilated	-2~8	3	ZEL	Dixell	R290	28
POS208SND	2025x800x1000	294	220-240/50	275	Ventilated	-2~8	2	ZEL	Dixell	R600a	28

REFRIGERATED PIZZA TABLE



SAS123N
SAS155N



SAS182N



- American fashionable style Saladette
- Impressive Performance with low power consumption (environmentally friendly)
- The cover is lockable
- Revisable self-closing door
- Full length stainless steel handle
- Adjustable feet or caster wheels
- Automatic defrost
- With stainless steel lid
- Rounded inner corners

Model	Product Dim (W/D/H mm)	Net capacity (L)	Voltage /Frequency(V/Hz)	Power (W)	Cooling system	Temp(°C)	Shelves No.	Compressor	Digital thermostat	Refrigerant	40 HQ Container loading
SAS123N	1230x770x1153	390	220-240/50	245	Ventilated	1~5	2	Embraco	Dixell	R290	34
SAS155N	1555x770x1153	504	220-240/50	300	Ventilated	1~5	2	Embraco	Dixell	R290	26
SAS182N	1830x770x1153	600	220-240/50	365	Ventilated	1~5	3	Embraco	Dixell	R290	26



DTS1500NOD#GSDTS1500O



STS1500NOD#GSSTS1500O

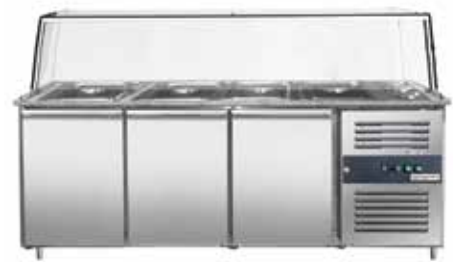

STS2000NOD#GSSTS2000O

- Revisable self-closing door
- Temperature setting via digital display
- Impressive performance With low power consumption (environmentally friendly)
- Full length stainless steel handle
- Adjustable feet or caster wheels
- Automatic defrost
- Granit working surface
- With cornered glass top
- Rounded inner corners



Model	Product Dim (W/D/H mm)	Net Capacity (L)	Voltage /Frequency(V/Hz)	Power (W)	Cooling System	Temp(°C)	Shelves No.	Compressor	Digital thermostat	Refrigerant	40 HQ Container Loading
DTS1500NOD#GSDTS1500O	1510x800x1167	294	220-240/50	428	Ventilated	-2~8	2	ZEL	dixell	R290	30
DTS2000NOD#GSDTS2000O	2020x800x1167	456	220-240/50	428	Ventilated	-2~8	3	ZEL	dixell	R290	28
STS1500NOD#GSSTS1500O	1510x800x1285	294	220-240/50	428	Ventilated	-2~8	2	ZEL	dixell	R290	30
STS2000NOD#GSSTS2000O	2020x800x1285	456	220-240/50	428	Ventilated	-2~8	3	ZEL	dixell	R290	28

PROFESSIONAL REFRIGERATION

DEEP FREEZER DRAWER CABINET



TSSH121

TSSH221

TSSH1121

TSSH2121

- Full length stainless steel handle
- Adjustable feet or caster wheels
- Automatic defrost
- Easy to clean
- Can be changed between chiller and freezer by pressing button
- Compact and space-saving
- High quality workmanship

Model	Product Dim (W/D/H mm)	Net Capacity (L)	Voltage /Frequency(V/Hz)	Power(W)	Cooling System	Temp(°C)	Compressor	Digital thermostat	Refrigerant	40 HQ Container Loading
TSSH121	905x700x600	51	220-240/50	240	ventilated	-18~-22	Embraco	Dixell	R290	108
TSSH221	905x700x865	102	220-240/50	460	ventilated	-18~-22	Embraco	Dixell	R290	72
TSSH1121	1230x700x600	77	220-240/50	270	ventilated	-18~-22	Embraco	Dixell	R290	81
TSSH2121	1230x700x865	154	220-240/50	500	ventilated	-18~-22	Embraco	Dixell	R290	54

REFRIGERATED SALADETTE



SAJ47

SAJ47E

SAJ47E2

- Full length stainless steel handle
- Lower energy consumption due to high-quality insulation
- CFC-free polyurethane insulation
- Automatic defrost
- Easy to clean
- Replaceable magnetic seal
- Compartment size: GN 1/1
- Optional for polyurethane cutting board (SAJ47)

Model	Product Dim (W/D/H mm)	Net capacity (L)	Voltage /Frequency(V/Hz)	Power (W)	Cooling system	Temp(°C)	Shelves No.	Compressor	Digital thermostat	Refrigerant	40 HQ Container loading
SAJ47	450x700x876	80	220-240/50	150	Static	2~8	1	Donper	Dixell	R600a	144
SAJ47E	450x700x876	80	220-240/50	150	Static	2~8	1	Donper	Dixell	R600a	144
SAJ47E2	450x700x876	80	220-240/50	150	Static	2~8	0	Donper	Dixell	R600a	144



SAG97ND

SAG147ND

- Full length stainless steel handle
- Impressive performance with low power consumption (environmentally friendly)
- Automatic defrost
- Easy to clean
- Replaceable magnetic seal
- Compartment size: GN 1/1
- Stainless steel workspace
- With polyurethane cutting board

Model	Product Dim (W/D/H mm)	Net capacity (L)	Voltage /Frequency(V/Hz)	Power (W)	Cooling system	Temp(°C)	Shelves No.	Compressor	Digital thermostat	Refrigerant	40 HQ Container loading
SAG97ND	900x700x876	213	220-240/50	160	Static	2~8	2	Donper	Dixell	R600a	72
SAG147ND	1365x700x850	342	220-240/50	260	Static	2~8	3	Donper	Dixell	R290	48

REFRIGERATED SALADETTE



- Full length stainless steel handle
- Automatic defrost
- Easy to clean
- Replaceable magnetic seal
- Compartment size: GN 1/1
- Stainless steel workspace
- Surface with upstand is optional



SAG97EAND

SAG147EAND

SAG97END

SAG147END

SAG97E2ND

SAG97E4ND

Model	Product Dim (W/D/H mm)	Net Capacity (L)	Voltage /Frequency(V/Hz)	Power(W)	Cooling System	Temp(°C)	Shelves No.	Compressor	Digital thermostat	Refrigerant	40 HQ Container Loading
SAG97EAND	900x700x976	179	220-240/50	160	Static	2~8	2	Donper	Dixell	R600a	72
SAG147EAND	1365x700x950	218	220-240/50	260	Static	2~8	3	Donper	Dixell	R290	48
SAG97END	900x700x876	179	220-240/50	160	Static	2~8	2	Donper	Dixell	R600a	72
SAG147END	1365x700x850	218	220-240/50	260	Static	2~8	3	Donper	Dixell	R290	48
SAG97E2ND	900x700x876	163	220-240/50	160	Static	2~8	1	Donper	Dixell	R600a	72
SAG97E4ND	900x700x876	100	220-240/50	160	Static	2~8	/	Donper	Dixell	R600a	72

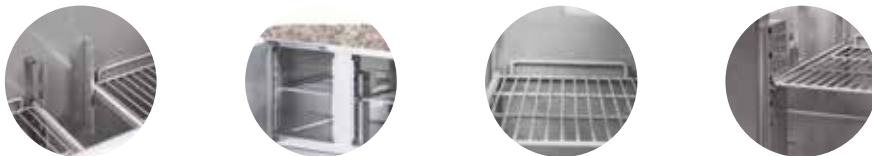

- Full length stainless steel handle
- Automatic defrost
- Easy to clean
- Replaceable magnetic seal
- Compartment size: GN 1/1
- Compatible for GN1/6 pans (5 or 8pcs)
- Granit working surface
- Stainless steel framework construction
- Optional for stainless steel or glass cover



SAG97GND

SAG147GND

SAG97OG#GSG97E

SAG147OG#GSG147E

Model	Product Dim (W/D/H mm)	Net Capacity (L)	Voltage /Frequency(V/Hz)	Power(W)	Cooling System	Temp(°C)	Shelves No.	Compressor	Digital thermostat	Refrigerant	40 HQ Container Loading
SAG97GND	900x700x1086	213	220-240/50	160	Static	2~8	2	Donper	Dixell	R600a	72
SAG147GND	1365x700x1075	342	220-240/50	260	Static	2~8	3	Donper	Dixell	R290	48
SAG97OG#GSG97E	900x700x906	213	220-240/50	160	Static	2~8	2	Donper	Dixell	R600a	72
SAG147OG#GSG147E	1365x700x895	342	220-240/50	260	Static	2~8	3	Donper	Dixell	R290	48

PROFESSIONAL REFRIGERATION

REFRIGERATED SALADETTE



SAG97AND



SAG147AND



- Full length stainless steel handle
- Impressive performance with low power consumption (environmentally friendly)
- Automatic defrost
- Easy to clean
- Replaceable magnetic seal
- Compartment size: GN 1/1
- Compatible for GN1/6 pans (5 or 8pcs)
- Stainless steel working surface

Model	Product Dim (W/D/H mm)	Net capacity (L)	Voltage /Frequency(V/Hz)	Power (W)	Cooling system	Temp(°C)	Shelves No.	Compressor	Digital thermostat	Refrigerant	40 HQ Container loading
SAG97AND	900x700x1040	179	220-240/50	160	Static	2~8	2	Donper	Dixell	R600a	72
SAG147AND	1370x700x1040	218	220-240/50	260	Static	2~8	3	Donper	Dixell	R290	48

- Full length stainless steel handle
- Easy to clean
- Replaceable magnetic seal
- Compartment size: GN 1/1
- Granite working surface with upstand
- Stainless steel framework construction
- Doors with soft open/close mechanism



POG97ND



POG147ND

Model	Product Dim (W/D/H mm)	Net Capacity (L)	Voltage /Frequency(V/Hz)	Power (W)	Cooling System	Temp(°C)	Shelves No.	Compressor	Digital thermostat	Refrigerant	40 HQ Container Loading
POG97ND	920x700x1040	213	220-240/50	160	Ventilated	2~8	2	Donper	Dixell	R600a	72
POG147ND	1400x700x1020	342	220-240/50	260	Ventilated	2~8	3	Donper	Dixell	R290	48



SAG97DRG#GSG97



SAG147DRG#GSG147

- Full length stainless steel handle
- Automatic defrost
- Easy to clean
- Replaceable magnetic seal
- Compartment size: GN 1/1
- With curved glass cover

Model	Product Dim (W/D/H mm)	Net Capacity (L)	Voltage /Frequency(V/Hz)	Power (W)	Cooling System	Temp(°C)	Shelves No.	Compressor	Digital thermostat	Refrigerant	40 HQ Container Loading
SAG97DRG #GSG97	900x700x1315	213	220-240/50	160	Ventilated	2~8	2	Donper	Dixell	R600a	72
SAG147DRG #GSG147	1368x700x1350	342	220-240/50	260	Ventilated	2~8	3	Donper	Dixell	R290	48

REFRIGERATED COOL DISPLAY



AGG204ND



AGG204END

- Optional for stainless steel lid or glass cover
- Compatible for GN1/3 or GN1/4 pans for different series
- Electronic temperature control
- Digital thermostat
- Easy to clean

Model	Product Dim (W/D/H mm)	Net capacity (L)	Voltage /Frequency(V/Hz)	Power (W)	Cooling system	Temp(°C)	Compressor	Digital thermostat	Refrigerant	40 HQ Container loading
AGG123ND	1200x335x435	5xGN1/4	220-240/50	160	Static	2~8	Donper	Dixell	R600a	386
AGG143ND	1400x335x435	6xGN1/4	220-240/50	160	Static	2~8	Donper	Dixell	R600a	336
AGG153ND	1500x335x435	7xGN1/4	220-240/50	160	Static	2~8	Donper	Dixell	R600a	310
AGG163ND	1600x335x435	7xGN1/4	220-240/50	160	Static	2~8	Donper	Dixell	R600a	294
AGG183ND	1800x335x435	8xGN1/4	220-240/50	160	Static	2~8	Donper	Dixell	R600a	260
AGG203ND	2000x335x435	10xGN1/4	220-240/50	200	Static	2~8	Donper	Dixell	R600a	242
AGG124ND	1200x395x435	4xGN1/3	220-240/50	160	Static	2~8	Donper	Dixell	R600a	323
AGG144ND	1400x395x435	6xGN1/3	220-240/50	160	Static	2~8	Donper	Dixell	R600a	280
AGG154ND	1500x395x435	6xGN1/3	220-240/50	160	Static	2~8	Donper	Dixell	R600a	261
AGG164ND	1600x395x435	7xGN1/3	220-240/50	160	Static	2~8	Donper	Dixell	R600a	247
AGG184ND	1800x395x435	8xGN1/3	220-240/50	160	Static	2~8	Donper	Dixell	R600a	218
AGG204ND	2000x335x435	9xGN1/3	220-240/50	200	Static	2~8	Donper	Dixell	R600a	196
AGG123END	1200x335x280	5xGN1/4	220-240/50	160	Static	2~8	Donper	Dixell	R600a	386
AGG143END	1400x335x280	6xGN1/4	220-240/50	160	Static	2~8	Donper	Dixell	R600a	336
AGG153END	1500x335x280	7xGN1/4	220-240/50	160	Static	2~8	Donper	Dixell	R600a	310
AGG163END	1600x335x280	7xGN1/4	220-240/50	160	Static	2~8	Donper	Dixell	R600a	294
AGG183END	1800x335x280	8xGN1/4	220-240/50	160	Static	2~8	Donper	Dixell	R600a	260
AGG203END	2000x335x280	10xGN1/4	220-240/50	200	Static	2~8	Donper	Dixell	R600a	242
AGG124END	1200x395x280	4xGN1/3	220-240/50	160	Static	2~8	Donper	Dixell	R600a	323
AGG144END	1400x395x280	6xGN1/3	220-240/50	160	Static	2~8	Donper	Dixell	R600a	280
AGG154END	1500x395x280	6xGN1/3	220-240/50	160	Static	2~8	Donper	Dixell	R600a	261
AGG164END	1600x395x280	7xGN1/3	220-240/50	160	Static	2~8	Donper	Dixell	R600a	247
AGG184END	1800x395x280	8xGN1/3	220-240/50	160	Static	2~8	Donper	Dixell	R600a	218
AGG204END	2000x395x280	9xGN1/3	220-240/50	200	Static	2~8	Donper	Dixell	R600a	196

PROFESSIONAL REFRIGERATION

UPRIGHT CHILLER/FREEZER



- European fashionable style upright cabinet chiller/freezer
- Impressive performance with low power consumption (environmentally friendly)
- Exceptionally efficient cooling motor
- Magnetic sealing strip keeps the cold air inside
- Inner box curved edges for easy cleaning
- Reversible self-closing door
- LED light
- Automatic defrost

Model	Product Dim (W/D/H mm)	Net Capacity (L)	Voltage /Frequency(V/Hz)	Power (W)	Cooling System	Temp(°C)	Shelves No.	Compressor	Digital thermostat	Refrigerant	40 HQ Container Loading
KSS400H	605x604x1854	239	220-240/50	185	Static with fan	-2~8	4	Wanbao	Elitech	R600a	54
TKSS400H	605x604x1854	254	220-240/50	150	Static	-10~-25	7	Wanbao	Elitech	R600a	54
KSS600H	782x715x1895	443	220-240/50	185	Static with fan	-2~8	4	Wanbao	Elitech	R600a	42
TKSS600H	782x715x1895	465	220-240/50	300	Static	-10~-25	7	Wanbao	Elitech	R600a	42

- European fashionable style upright cabinet chiller/freezer
- Impressive performance with low power consumption (environmentally friendly)
- Magnetic sealing strip keeps the cold air inside.
- Inner box curved edges for easy cleaning
- Reversible self-closing door
- Adjustable feet or caster wheels
- With lock and key
- LED light
- Numerous storage options
- Changeable door hinge
- Exceptionally efficient cooling motor



Model	Product Dim (W/D/H mm)	Net Capacity (L)	Voltage /Frequency(V/Hz)	Power (W)	Cooling System	Temp(°C)	Shelves No.	Compressor	Digital thermostat	Refrigerant	40 HQ Container Loading
KSS400N	595x653x1840	239	220-240/50	215	Ventilated	0~8	3+1	ZEL	Dixell	R600a	54
KSS600SRN	775x723x1840	376	220-240/50	228	Ventilated	0~8	3+1	ZEL	Dixell	R600a	42
TKSS400N	595x653x1840	206	220-240/50	425	Ventilated	-10~-22	6+1	ZEL	Dixell	R290	54
TKSS600SRN	775x723x1840	321	220-240/50	492	Ventilated	-10~-22	6+1	Cubigei	Dixell	R290	42

UPRIGHT CHILLER/FREEZER

- European fashionable style upright cabinet chiller
- Impressive performance with low power consumption (environmentally friendly)
- Magnetic sealing strip keeps the cold air inside.
- Inner box curved edges for easy cleaning
- Reversible self-closing door
- Adjustable feet or caster wheels
- With lock and key
- LED light
- Large storage capacity
- Numerous storage options
- Glass door



KSS400GN



KSS600GN

Model	Product Dim (W/D/H mm)	Net capacity (L)	Voltage /Frequency(V/Hz)	Power (W)	Cooling system	Temp(°C)	Shelves No.	Compressor	Digital thermostat	Refrigerant	40 HQ Container loading
KSS400GN	595x635x1840	239	220-240/50	215	Ventilated	0~8	3+1	ZEL	Dixell	R600a	54
KSS600GN	775x705x1840	376	220-240/50	228	Ventilated	0~8	3+1	ZEL	Dixell	R600a	42

- European fashionable style upright cabinet chiller
- Impressive performance with low power consumption (environmentally friendly)
- Magnetic sealing strip keeps the cold air inside.
- Inner box curved edges for easy cleaning
- Reversible self-closing door
- Adjustable feet or caster wheels
- With lock and key
- LED light
- Large storage capacity
- Numerous storage options
- Glass door



KSS400HGN



KSS600HGN

Model	Product Dim (W/D/H mm)	Net capacity (L)	Voltage /Frequency(V/Hz)	Power (W)	Cooling system	Temp(°C)	Shelves No.	Compressor	Digital thermostat	Refrigerant	40 HQ Container loading
KSS400HGN	605x604x1854	246	220-240/50	185	Static with fan	2~8	3+1	Wanbao	Elitech	R600a	54
KSS600HGN	782x715x1895	414	220-240/50	185	Static with fan	2~8	3+1	Wanbao	Elitech	R600a	42

- European fashionable style upright cabinet chiller/freezer
- Impressive performance with low power consumption (environmentally friendly)
- Magnetic sealing strip keeps the cold air inside.
- Inner box curved edges for easy cleaning
- Digital control thermostat
- Convenient to move
- Ideal solution for professional use
- Compact and space-saving



KSS200H



TKSS200H

Model	Product Dim (W/D/H mm)	Net capacity (L)	Voltage /Frequency(V/Hz)	Power (W)	Cooling system	Temp(°C)	Shelves No.	Compressor	Digital thermostat	Refrigerant	40 HQ Container loading
KSS200H	605x604x855	66	220-240/50	100	Static with fan	-2~8	3	Wanbao	Elitech	R600a	108
TKSS200H	605x604x855	78	220-240/50	105	Static	-10~-25	3	Wanbao	Elitech	R600a	108

PROFESSIONAL REFRIGERATION

BLAST CHILLER/FREEZER

- Magnetic sealing strip keeps the cold air inside
- Convenient to move
- Ideal solution for professional use
- Compact and space-saving
- Compatible for both GN pans and bakery pans
- With food probe inside
- Adjustable shelf
- Adjustable feet
- Easy to clean



SFHA3

Model	Product Dim (W/D/H mm)	Net capacity (L)	Voltage /Frequency (V/Hz)	Power (W)	Cooling system	Temp(°C)	Pans No.	Compressor	Refrigerant	40 HQ Container loading
SFHA3	760x730x850	95	220-240/50	749	Fan cooling	-40 ~ 10	5	Secop	R290	126

MINI BAR - ICE FREEZER



black shelf
METKHA449S



white shelf

- Triple layer glass door with electric heating
- Thickened insulation layer, with good insulation effect
- With lock and key
- Door with soft open/close mechanism
- Changeable door hinge
- Especially suitable for use in hotels, restaurants, snack bars etc.METKHA449S With LCD screen,
- You can play animation



black shelf



white shelf

METKHA448S

Model	Product Dim (W/D/H mm)	Net capacity (L)	Voltage /Frequency(V/Hz)	Power (W)	Cooling system	Temp(°C)	Shelves No.	Compressor	Digital thermostat	Refrigerant	40 HQ Container loading
METKHA449S	460x440x920	50	220-240/50	220	Static	-16~-18	3	Wanbao	Dixell	R290	176
METKHA448S	460x440x815	50	220-240/50	170	Static	-16~-18	3	Wanbao	Dixell	R290	176

MINI FRIDGE

- Magnetic sealing strip keeps the cold air inside
- Perfect for hotels, camping sites and offices etc.
- Compact and space-saving
- Automatic defrost
- Adjustable feet
- Easy to clean
- With lock and key



MBKD1TK



MBKD1GTK



MBKD1GTK-ZA

Model	Product Dim (W/D/H mm)	Net capacity (L)	Voltage /Frequency(V/ Hz)	Power(W)	Cooling system	Temp(°C)	Shelves No.	Refrigerant	40 HQ Container loading
MBKD1TK	402x455x560	36	220-240/50	65	Absorption	0~10	2	R717	424
MBKD1GTK	402x455x560	34	220-240/50	65	Absorption	4~12	2	R717	424
MBKD1GTK-ZA	402x455x560	34	220-240/50	65	Absorption	4~12	2	R717	424

MINI FRIDGE

- European fashionable style drinks refrigerator
- Magnetic sealing strip keeps the cold air inside.
- Inner box curved edges for easy cleaning
- Reversible self-closing door
- Especially suitable for use in hotels, restaurants, snack bars etc.
- Adjustable feet
- Automatic defrost
- Glass door with double glazing
- With recessed handle
- Easy to clean
- LED light



MBKX136BSN

MBKX136WN

MBKX136RN

Model	Product Dim (W/D/H mm)	Net capacity (L)	Voltage /Frequency (V/Hz)	Power (W)	Cooling system	Temp(°C)	Shelves No.	Compressor	Refrigerant	40 HQ Container loading
MBKX136BSN	495x525x825	113	220-240/50	110	Static with fan	0~10	3	Wanbao	R600a	160
MBKX136WN	495x525x825	113	220-240/50	110	Static with fan	0~10	3	Wanbao	R600a	160
MBKX136RN	495x525x825	113	220-240/50	110	Static with fan	0~10	3	Wanbao	R600a	160

BACKBAR COOLER



BKTG1S



BKTG2S



BKTG3S

- Manufactured in accordance with relevant hygiene and safety standards
- Materials comply with European food safety standards
- Glass with Low-E
- Digital thermostat
- LED light
- Easy to clean



BKTG220SS



BKTG320SS

Model	Product Dim (W/D/H mm)	Net capacity (L)	Voltage /Frequency (V/Hz)	Power (W)	Cooling system	Temp (°C)	Shelves No.	Compressor	Door Type	Exterior/Interior color	Refrigerant	40 HQ Container loading
BKTG1S	600x505x895	126	220-240/50,60	250	Static with fan	2~8	2	Huayi	Hinged door	Black/ White	R600a	136
BKTG2S	900x505x895	220	220-240/50,60	280	Static with fan	2~8	2	Huayi	Hinged door	Black/ White	R600a	96
BKTG3S	1335x505x895	320	220-240/50,60	350	Static with fan	2~8	2	Huayi	Hinged door	Black/ White	R600a	66
BKTG220SS	900x505x895	220	220-240/50,60	280	Static with fan	2~8	2	Huayi	Sliding door	Black/ White	R600a	96
BKTG320SS	1335x505x895	320	220-240/50,60	350	Static with fan	2~8	2	Huayi	Sliding door	Black/ White	R600a	66

PROFESSIONAL REFRIGERATION

BACKBAR COOLER



BKG605E



BKG905E



BKG135E

Model	Product Dim (W/D/H mm)	Net capacity (L)	Voltage /Frequency (V/Hz)	Power (W)	Cooling system	Temp(°C)	Shelves No.	Compressor	Door Type	Exterior/ Interior color	Refrigerant	40 HQ Container loading
BKG605E	600x505x895	126	220-240/50,60	250	Static with fan	2~8	2	Huayi	Hinged door	SS/white	R600a	136
BKG905E	900x505x895	220	220-240/50,60	280	Static with fan	2~8	2	Huayi	Hinged door	SS/white	R600a	96
BKG135E	1335x505x895	320	220-240/50,60	350	Static with fan	2~8	2	Huayi	Hinged door	SS/white	R600a	66



BKTG220S



BKTG320S



BKTG220E



BKTG320E



BKTSTG220



BKTSTG320

- Manufactured in accordance with relevant hygiene and safety standards
- Materials comply with European food safety standards
- Glass with Low-E
- Digital thermostat
- LED light
- Easy to clean

Model	Product Dim (W/D/H mm)	Net capacity (L)	Voltage /Frequency (V/Hz)	Power (W)	Cooling system	Temp(°C)	Shelves No.	Compressor	Door Type	Exterior/ Interior color	Refrigerant	40 HQ Container loading
BKTG220S	900x505x895	220	220-240/50	280	Static with fan	2~8	2	Huayi	Hinged door	Black/ Black	R600a	96
BKTG320S	1335x505x895	320	220-240/50	350	Static with fan	2~8	2	Huayi	Hinged door	Black/ Black	R600a	66
BKTG220E	900x505x895	220	220-240/50	280	Static with fan	2~8	2	Huayi	Hinged door	Gray/Gray	R600a	96
BKTG320E	1335x505x895	320	220-240/50	350	Static with fan	2~8	2	Huayi	Hinged door	Gray/Gray	R600a	66
BKTSTG220	900x505x895	220	220-240/50	280	Static with fan	2~8	2	Huayi	Sliding door	Black/ Black	R600a	96
BKTSTG320	1335x505x895	320	220-240/50	350	Static with fan	2~8	2	Huayi	Sliding door	Black/ Black	R600a	66

BEVERAGE COOLER

- Mechanical temperature control
- Hips interior line
- Fan cooling-Nofrost
- Lock and key
- Adjustable shelves
- Double tempered glass door
- LED lighting
- Illuminated canopy
- Ventilated free maintenance condenser
- Front air blowing design to prevent glass condensation
- 4 adjustable feet
- Recessed handle



GX352N



GX352SN

Model	Product Dim (W/D/H mm)	Net capacity (L)	Voltage /Frequency (V/Hz)	Power (W)	Cooling system	Temp(°C)	Shelves No.	Compressor	Refrigerant	40 HQ Container loading
GX352N	615x590x1945	352	220-240/50	350	Ventilated	1~7	4	Wanbao	R600a	54
GX352SN	615x590x1945	352	220-240/50	350	Ventilated	1~7	4	Wanbao	R600a	54

- Automatic defrost system
- Interior Vertical light
- Adjustable shelves
- Double glazed glass door
- Numerous storage options
- 2 integrated castors and 2 fixed feet make the refrigerator flexible
- Lock and key



GKS330N

Model	Product Dim (W/D/H mm)	Net capacity (L)	Voltage /Frequency (V/Hz)	Power (W)	Cooling system	Temp(°C)	Shelves No.	Compressor	Digital thermostat	Refrigerant	40 HQ Container loading
GKS330N	595x645x1905	320	220-240/50	210	Ventilated	2~8	4	Qianjiang	Dixell	R600a	54

- Awesome for display and advertising with your logo
- Adjustable shelves
- Even inside temperature
- Double glazed glass door
- Numerous storage options



GKS160S



GKS160W

Model	Product Dim (W/D/H mm)	Net capacity (L)	Voltage /Frequency (V/Hz)	Power (W)	Cooling system	Temp(°C)	Shelves No.	Compressor	Digital thermostat	Refrigerant	40 HQ Container loading
GKS160S	390x480x1888	142	220-240/50	150	Static	2~8	5	ZEL/Meizhi	Dixel/Mechanical	R600a	115
GKS160W	390x480x1888	142	220-240/50	150	Static	2~8	5	ZEL/Meizhi	Dixel/Mechanical	R600a	115

PROFESSIONAL REFRIGERATION

BEVERAGE COOLER

- Automatic defrost system
- Door with soft open/close mechanism
- Impressive performance with low power consumption (environmentally friendly)
- Interior vertical light
- Adjustable shelves
- Double glazed glass doors
- Numerous storage options
- Lock and key



GKS630FNN



GKS630FNN-B



GKS908N



GKS908N-B



GKS908NK



GKS908NK-B



GKS1500S

Model	Product Dim (W/D/H mm)	Net capacity (L)	Voltage /Frequency (V/Hz)	Power (W)	Cooling system	Temp(°C)	Shelves No.	Compressor	Door Type	Exterior/Interior color	Refrigerant	40 HQ Container loading
GKS630FNN	925x695x1945	575	220-240/50	350	Ventilated	2~8	8	Cubigel	Hinged door	White/White with black door frame	R290	35
GKS630FNN-B	925x695x1945	575	220-240/50	350	Ventilated	2~8	8	Cubigel	Hinged door	Black/Black	R290	35
GKS908N	1295x695x1945	880	220-240/50	360	Ventilated	2~8	8	Cubigel	Sliding door	White/White with black door frame	R290	25
GKS908N-B	1295x695x1945	880	220-240/50	360	Ventilated	2~8	8	Cubigel	Sliding door	Black/Black	R290	25
GKS908NK	1295x695x1945	880	220-240/50	360	Ventilated	2~8	8	Cubigel	Hinged door	White/White with black door frame	R290	25
GKS908NK-B	1295x695x1945	880	220-240/50	360	Ventilated	2~8	8	Cubigel	Hinged door	Black/Black	R290	25
GKS1500S	2050x740x1995	1560	220-240/50	739	Ventilated	2~8	12	Cubigel	Hinged door	Black/Black	R290	15

BOTTLE REFRIGERATOR

- Automatic defrost function
- Impressive performance with low power consumption (environmentally friendly)
- Black painted exterior, electroplated aluminum interior
- 5 layers of chromed shelf
- Toughened glass door
- With light and lock
- Optional plastic coated shelf or mechanical controller



FKSG651N



FKSG951N

Model	Product Dim (W/D/H mm)	Net capacity (L)	Voltage /Frequency (V/Hz)	Power (W)	Cooling system	Temp(°C)	Shelves No.	Compressor	Digital thermostat	Refrigerant	40 HQ Container loading
FKSG651N	600x515x1815	292	220-240/50	245	Ventilated	2~8	5	Secop	Dixell	R290	54
FKSG951N	920x515x1815	466	220-240/50	390	Ventilated	2~8	10	Secop	Dixell	R290	42

MULTIDECK

- Impressive performance with low power consumption (environmentally friendly)
- Digital temperature control
- Automatic defrost
- Automatic water drainage control
- Quiet operation
- Doors with soft open/close mechanism
- Easy to clean



WKS710SM

Model	Product Dim (W/D/H mm)	Net capacity (L)	Voltage /Frequency (V/Hz)	Power (W)	Cooling system	Temp(°C)	Shelves No.	Compressor	Digital thermostat	Refrigerant	40 HQ Container loading
WKS420SM	1000x660x2000	360	220-240/50	980	Ventilated	2~8	4 pcs	Secop	Dixell	R290	30
WKS560SM	1310x660x2000	470	220-240/50	1040	Ventilated	2~8	4 pcs	Secop	Dixell	R290	24
WKS710SM	1500x660x2000	540	220-240/50	1070	Ventilated	2~8	4 pcs	Secop	Dixell	R290	21
WKS840SM	1935x660x2000	720	220-240/50	1160	Ventilated	2~8	8 pcs	Secop	Dixell	R290	15

REFRIGERATED DISPLAY CABINETS FOR MEAT

- Impressive performance with low power consumption (environmentally friendly)
- Square glass front
- Two sliding windows
- Adjustable feet
- LED light
- With lock and key
- Easy to clean



KFTH128



KFTH158

Model	Product Dim (W/D/H mm)	Net capacity (L)	Voltage /Frequency (V/Hz)	Power (W)	Cooling system	Temp(°C)	Compressor	Digital thermostat	Refrigerant	40 HQ Container loading
KFTH128	1280x975x1295	144	220-240/50	760	Ventilated	2~8	Secop	Dixell	R290	32
KFTH158	1580x975x1295	180	220-240/50	760	Ventilated	2~8	Secop	Dixell	R290	28
KFTH188	1880x975x1295	216	220-240/50	760	Ventilated	2~8	Secop	Dixell	R290	24
KFTH248	2480x975x1295	288	220-240/50	760	Ventilated	2~8	Secop	Dixell	R290	16

WALL CABINET

- Digital controller
- Automatic defrost
- LED light
- With night curtain
- Adjustable shelves
- With price label setting
- Automatic drain water



WKS165



WKS190N

Model	Product Dim (W/D/H mm)	Net capacity (L)	Voltage /Frequency (V/Hz)	Power (W)	Cooling system	Temp(°C)	Shelves No.	Compressor	Digital thermostat	Refrigerant	40 HQ Container loading
WKS165	660x700x1450	165	220-240/50	700	Ventilated	-1~7	2	Embraco/Secop	Dixell	R290	48
WKS190N	706x717x1500	165	220-240/50	550	Ventilated	-1~7	3	Embraco/Secop	Dixell	R290	42

REFRIGERATED ISLAND

- Impressive performance with low power consumption (environmentally friendly)
- Automatic defrost
- More display area
- Easy to clean



Model	Product Dim (W/D/H mm)	Net capacity (L)	Voltage /Frequency (V/Hz)	Power (W)	Cooling system	Temp(°C)	Compressor	Digital thermostat	Refrigerant	40 HQ Container loading
KTHS190	1370x1080x935	190	220-240/50	850	Ventilated	-1~7	Embraco/Secop	Dixell	R290	32

REFRIGERATED SHELVES

- Excellently suited for use in professional kitchens
- LED lighting
- Adjustable shelves
- Automatic defrost
- Including night shutters
- Easy to clean



WKRN220N



WKR420

Model	Product Dim (W/D/H mm)	Net capacity (L)	Voltage /Frequency (V/Hz)	Power (W)	Cooling system	Temp(°C)	Shelves No.	Compressor	Digital thermostat	Refrigerant	40 HQ Container loading
WKRN220N	494x674x1742	220	220-240/50	1300	Ventilated	2~10	3	Embraco	Pengjia	R290	64
WKR420	700x670x1900	375	220-240/50	660	Ventilated	2~8	3	Secop	Dixell	R290	48

PANORAMA DISPLAY CASE

- With digital temperature display
- Top light
- Adjustable shelves
- 4 sides with double glazing
- Automatic defrost
- Ventilated cooling system
- Easy to clean



Model	Product Dim (W/D/H mm)	Net capacity (L)	Voltage /Frequency (V/Hz)	Power (W)	Cooling system	Temp(°C)	Shelves No.	Compressor	Refrigerant	40 HQ Container loading
PVNR72S	428x386x885	68	220-240/50	180	Ventilated	0~12	3	ZEL	R600a	252
PVNR72E	428x386x885	68	220-240/50	180	Ventilated	0~12	3	ZEL	R600a	252
PVNR98S	428x386x1110	98	220-240/50	180	Ventilated	0~12	4	ZEL	R600a	250
PVNR98E	428x386x1110	98	220-240/50	180	Ventilated	0~12	4	ZEL	R600a	250

- LED lighting
- 4 rotating round chrome grids
- 4 sides with double glazing
- Automatic defrost

- LED lighting
- 4 sides with double glazing
- Adjustable shelves
- Automatic defrost

- LED lighting
- 4 sides with triple glazing
- Adjustable shelves
- Automatic defrost



Model	Product Dim (W/D/H mm)	Net capacity (L)	Voltage /Frequency (V/Hz)	Power (W)	Cooling system	Temp(°C)	Shelves No.	Compressor	Refrigerant	40 HQ Container loading
PVNR108E	470x470x870	108	220-240/50	230	Ventilated	2~10	4	ZEL	R600a	168
PVNR235N	515x485x1690	235	220-240/50	380	Ventilated	0~12	4	Cubigel	R290	80
PVNR400N	650x650x1908	400	220-240/50	495	Ventilated	0~12	3	Embraco	R290	45

PROFESSIONAL REFRIGERATION

PANORAMA DISPLAY CASE

- Automatic defrosting cycle, and evaporation of defrost water
- Adjustable shelf
- Stainless steel base
- Rear hinge door
- 4 Sides with double glazing
- LED lighting



PVH550E3N
PVH550E3T2N



PVH550S3N
PVH550S3T2N

Model	Product Dim (W/D/H mm)	Net capacity (L)	Voltage /Frequency (V/Hz)	Power (W)	Cooling system	Temp(°C)	Shelves No.	Compressor	Digital thermostat	Refrigerant	40 HQ Container loading
PVH550E3N	675x695x1900	440	220-240/50	370	Ventilated	2~10	5	Embraco	Dixell	R290	48
PVH550S3N	675x695x1900	440	220-240/50	370	Ventilated	2~10	5	Embraco	Dixell	R290	48
PVH550E3T2N	675x695x1900	440	220-240/50	370	Ventilated	2~10	5	Embraco	Dixell	R290	48
PVH550S3T2N	675x695x1900	440	220-240/50	370	Ventilated	2~10	5	Embraco	Dixell	R290	48



PVNR72R

- LED light
- Rotatable shelves
- 4 sides with double glazing
- Automatic defrost



PVNR100R



- Glass shelves
- LED lighting
- Double glazing
- Door closes automatically
- Automatic defrost



PVNR400R

Model	Product Dim (W/D/H mm)	Net capacity (L)	Voltage /Frequency (V/Hz)	Power (W)	Cooling system	Temp(°C)	Shelves No.	Compressor	Refrigerant	40 HQ Container loading
PVNR72R	450x450x983	73	220-240/50	190	Ventilated	2~12	4	ZEL	R600a	168
PVNR100R	480x480x1030	100	220-240/50	210	Ventilated	2~8	3	ZEL	R600a	160
PVNR400R	680x680x1750	360	220-240/50	460	Ventilated	2~8	4	Embraco	R290	45

SUSHI SHOWCASE



SKAVNR513



SKAVNR512

- With a round glass showcase
- Interior lighting with LED lights
- High stability
- Excellent cooling performance
- Automatic defrost

Model	Product Dim (W/D/H mm)	Net capacity (L)	Voltage /Frequency (V/Hz)	Power (W)	Cooling system	Temp(°C)	Compressor	Refrigerant	40 HQ Container loading
SKAVNR513	1352x420x265	52	220-240/50	190	Static	0~12	ZEL	R600a	224
SKAVNR512	1800x420x265	132	220-240/50	190	Static	0~12	ZEL	R600a	168

TABLE DISPLAY CASE WITH SELF-SERVICE



KTH9225N
KTH1435N

- Suitable for self-service in supermarkets, restaurants and hotels
- Double glass with vacuum
- Digital thermostat
- Presentation area with LED lighting
- Stainless steel frame
- Rear sliding doors
- Front acrylic tipup doors

Model	Product Dim (W/D/H mm)	Net capacity (L)	Voltage /Frequency (V/Hz)	Power (W)	Cooling system	Temp(°C)	Shelves No.	Compressor	Digital thermostat	Refrigerant	40 HQ Container loading
KTH9225N	900x600x1000	225	220-240/50	450	Ventilated	2~10	2	Embraco	Dixell	R290	70
KTH1435N	1400x600x1000	350	220-240/50	670	Ventilated	2~10	2	Embraco	Dixell	R290	50

TABLE REFRIGERATED DISPLAY CASE

- High Transparent view
- Excellent performance
- Low power consumption
- Auto defogging by heated curved glass
- Easy to clean
- Low Noise
- Automatic Defrost



TKD95N
TKD125N
TKD155N



THD95
THD125
THD155

Model	Product Dim (W/D/H mm)	Net capacity (L)	Voltage /Frequency (V/Hz)	Power (W)	Cooling system	Temp(°C)	Shelves No.	Compressor	Digital thermostat	Refrigerant	40 HQ Container loading
TKD95N	900x550x790	128	220-240/50	450	Ventilated	2~8	1	Cubigel	Dixell	R290	82
TKD125N	1200x550x790	176	220-240/50	450	Ventilated	2~8	1	Cubigel	Dixell	R290	56
TKD155N	1500x550x790	224	220-240/50	550	Ventilated	2~8	1	Cubigel	Dixell	R290	52
THD95	900x550x790	128	220-240/50	770	/	45~65	1	/	Shangfang	/	82
THD125	1200x550x790	176	220-240/50	800	/	45~65	1	/	Shangfang	/	56
THD155	1500x550x790	224	220-240/50	850	/	45~65	1	/	Shangfang	/	52

PROFESSIONAL REFRIGERATION

TABLE REFRIGERATED DISPLAY CASE



TKVNR100



TKVNR120
TKVNR160



TKVNR108E

- Curved front glass
- LED lighting
- Adjustable shelves
- 4 sides with double glazing
- With digital control
- Automatic defrost

- Ergonomic handle
- Digital control
- Automatic defrost
- Adjustable feet
- Elegant presentation of goods
- Food stays fresh longer

Model	Product Dim (W/D/H mm)	Net capacity (L)	Voltage /Frequency (V/Hz)	Power (W)	Cooling system	Temp(°C)	Shelves No.	Compressor	Refrigerant	40 HQ Container loading
TKVNR100	682x450x675	100	220-240/50	160	Ventilated	0~12	2	ZEL	R600a	189
TKVNR120	702x568x686	120	220-240/50	160	Ventilated	0~12	2	ZEL	R600a	162
TKVNR160	880x568x686	160	220-240/50	200	Ventilated	0~12	2	ZEL	R600a	126
TKVNR108E	695x882x417	118	220-240/50	105	Static	2~12	/	Donper	R600a	140



TKVGNR120



TKVGNR160



TKVGNR200



THVNR120



THVNR160



THVNR200

Model	Product Dim (W/D/H mm)	Net capacity (L)	Voltage /Frequency (V/Hz)	Power (W)	Cooling system	Temp(°C)	Shelves No.	Compressor	Refrigerant	40 HQ Container loading
TKVGNR120	702x568x686	120	220-240/50	160	Ventilated	0~12	2	ZEL	R600a	162
TKVGNR160	880x568x686	160	220-240/50	160	Ventilated	0~12	2	ZEL	R600a	126
TKVGNR200	1219x568x686	200	220-240/50	400	Ventilated	0~12	2	Cubigel	R290	84
THVNR120	678x568x686	120	220-240/50	1100	/	30~90	3	/	/	162
THVNR160	856x568x686	160	220-240/50	1500	/	30~90	3	/	/	126
THVNR200	1219x568x686	202	220-240/50	1800	/	30~90	3	/	/	84

CAKE SHOWCASE

- Sliding glass door for easy access to the interior
- Height-adjustable shelves
- Digital display
- Very good isolation
- LED lighting
- Highly robust
- Easy to clean
- All sides are made of glass



KTG107-SFN
KTG157-SFN
KTG207-SFN

Model	Product Dim (W/D/H mm)	Net capacity (L)	Voltage /Frequency (V/Hz)	Power (W)	Cooling system	Temp(°C)	Shelves No.	Compressor	Refrigerant	40 HQ Container loading
KTG107-SFN	1000x730x1200	223	220-240/50,60	450	Ventilated	2~8	2	Cubigel	R290	60
KTG157-SFN	1500x730x1200	278	220-240/50,60	550	Ventilated	2~8	2	Cubigel	R290	30
KTG207-SFN	2000x730x1200	325	220-240/50,60	650	Ventilated	2~8	2	Cubigel	R290	30



KTGSF107S
KTGSF157S
KTGSF207S



KTG107W
KTG127W
KTG157W
KTG187W

- Sliding glass door for easy access to the interior
- Height-adjustable shelves
- Digital display
- Very good isolation
- LED lighting
- Highly robust
- Easy to clean
- All sides are made of glass

LED OFF

Model	Product Dim (W/D/H mm)	Net capacity (L)	Voltage /Frequency (V/Hz)	Power (W)	Cooling system	Temp(°C)	Shelves No.	Compressor	Refrigerant	40 HQ Container loading
KTGSF107S	1000x730x1200	223	220-240/50,60	450	Ventilated	2~8	2	Cubigel	R290	60
KTGSF157S	1500x730x1200	278	220-240/50,60	550	Ventilated	2~8	2	Cubigel	R290	30
KTGSF207S	2000x730x1200	325	220-240/50,60	650	Ventilated	2~8	2	Cubigel	R290	30
KTG107W	1000x740x1900	850	220-240/50,60	825	Ventilated	2~8	3	Cubigel	R290	24
KTG127W	1200x740x1900	950	220-240/50,60	995	Ventilated	2~8	3	Cubigel	R290	24
KTG157W	1500x740x1900	1400	220-240/50,60	1255	Ventilated	2~8	3	Cubigel	R290	15
KTG187W	1800x740x1900	1850	220-240/50,60	1520	Ventilated	2~8	3	Cubigel	R290	15

PROFESSIONAL REFRIGERATION

CAKE SHOWCASE



KTH9713R
KTH12713R
KTH15713R
KTH18713R



KTH9712A
KTH12712A
KTH15712A
KTH18712A

- Front closed, rear with sliding doors
- Outer housing made of stainless steel
- Big presentation area made of glass
- Double glazing
- LED lighting
- Automatic defrost
- Easy to clean

Model	Product Dim (W/D/H mm)	Net capacity (L)	Voltage /Frequency (V/Hz)	Power (W)	Cooling system	Temp(°C)	Shelves No.	Compressor	Digital thermostat	Refrigerant	40 HQ Container loading
KTH9713R	900x740x1300	380	220-240/50	400	Ventilated	2~10	4	Embraco	Dixell	R290	28
KTH12713R	1200x740x1300	505	220-240/50	455	Ventilated	2~10	4	Embraco	Dixell	R290	23
KTH15713R	1500x740x1300	635	220-240/50	515	Ventilated	2~10	4	Embraco	Dixell	R290	14
KTH18713R	1800x740x1300	780	220-240/50	560	Ventilated	2~10	4	Embraco	Dixell	R290	14
KTH9712A	900x740x1200	370	220-240/50	400	Ventilated	2~10	3	Embraco	Dixell	R290	56
KTH12712A	1200x740x1200	495	220-240/50	445	Ventilated	2~10	3	Embraco	Dixell	R290	46
KTH15712A	1500x740x1200	620	220-240/50	515	Ventilated	2~10	3	Embraco	Dixell	R290	28
KTH18712A	1800x740x1200	760	220-240/50	540	Ventilated	2~10	3	Embraco	Dixell	R290	28



TKVH700R
TKVH900R



TKVH700
TKVH900

Model	Product Dim (W/D/H mm)	Net capacity (L)	Voltage /Frequency (V/Hz)	Power (W)	Cooling system	Temp(°C)	Shelves No.	Compressor	Digital thermostat	Refrigerant	40 HQ Container loading
TKVH700R	700x560x730	105	220-240/50	185	Ventilated	2~10	2	Jiaxipera	Dixell	R600a	171
TKVH900R	900x560x730	140	220-240/50	200	Ventilated	2~10	2	Jiaxipera	Dixell	R600a	126
TKVH700	700x560x730	120	220-240/50	185	Ventilated	2~10	2	Jiaxipera	Dixell	R600a	171
TKVH900	900x560x730	160	220-240/50	200	Ventilated	2~10	2	Jiaxipera	Dixell	R600a	126

ICE MAKER

- Quick production finished in several minutes
- Portable, and no fixed water connection required
- Easy operation, just fill water tank and select ice cube size
- Perfect for restaurants, cafes, bars and home etc.
- Alarm function for a low water level
- Alarm function for maximum ice cube capacity
- Easy to clean



EBRH12



EBSH12



Model	Product Dim (W/D/H mm)	Net capacity (L)	Voltage /Frequency (V/Hz)	Power (W)	Temp(°C)	Colour	Ice shape	Compressor	Refrigerant	40 HQ Container loading
EBRH12	242x358x328	2.2	220-240/50	90~100	-20	Red	Bullet shape	Huayi	R600a	1722
EBSH12	242x358x328	2.2	220-240/50	90~100	-20	Stainless steel	Bullet shape	Huayi	R600a	1722



EWBH345-N



EWBH356-N



EWBH556-N



EWBH569-N

- Cooling water reusing system to save energy
- Advanced self-checking controller to automatically control the whole recycled produce process
- Internal water cycling system to make more ice cube
- Powerful, continuous ice-making system
- Four adjustable feet
- Easy to use
- Easy to clean
- For bullet shaped ice

Model	Product Dim (W/D/H mm)	Net capacity (L)	Voltage /Frequency (V/Hz)	Power (W)	Ice making capacity(k-g/24h)	Cooling system	Ice shape	Compressor	Refrigerant	40 HQ Container loading
EWBH345-N	330x470x580	9.4	220-240/50	200	24	Air cooling	Bullet shape	Huajun	R290	464
EWBH356-N	398x510x610	13.5	220-240/50	240	28	Air cooling	Bullet shape	Huajun	R290	270
EWBH556-N	546x572x675	30	220-240/50	320	52	Air cooling	Bullet shape	Huajun	R290	108
EWBH569-N	500x612x910	52	220-240/50	600	80	Air cooling	Bullet shape	Huajun	R290	128



EFBH345-N



EFBH358-N



EFBH357-N



EFBH569-N

- Advanced self-checking controller to automatically control the whole recycled produce process
- Internal water cycling system to make more ice cube
- Powerful, continuous ice-making system
- Four adjustable feet
- Easy to clean
- For mineral salt shaped ice

Model	Product Dim (W/D/H mm)	Net capacity (L)	Voltage /Frequency (V/Hz)	Power (W)	Ice making capacity(k-g/24h)	Cooling system	Ice shape	Compressor	Refrigerant	40 HQ Container loading
EFBH345-N	330x470x580	9.4	220-240/50	240	30	Air cooling	Mineral salt shape	Huajun	R290	448
EFBH357-N	398x510x720	13.5	220-240/50	240	50	Air cooling	Mineral salt shape	Huajun	R290	300
EFBH358-N	398x510x832	25	220-240/50	380	85	Air cooling	Mineral salt shape	Huajun	R290	200
EFBH569-N	500x612x960	52	220-240/50	400	100	Air cooling	Mineral salt shape	Huajun	R290	128

PROFESSIONAL REFRIGERATION

ICE MAKER



EWBH345W-N



EWBH356W-N

- Water cooling system allows device to be used in high ambient temperatures
- Powerful, continuous cooling
- Extremely quiet due to water cooling
- Automatic control of ice cube production
- Efficient insulation injected under high pressure
- Front ventilation
- Easy to use
- Easy to clean
- For bullet shaped ice

Model	Product Dim (W/D/H mm)	Net capacity (L)	Voltage /Frequency (V/Hz)	Power (W)	Ice making capacity (kg/24h)	Cooling system	Ice shape	Compressor	Refrigerant	40 HQ Container loading
EWBH345W-N	330x470x580	9.4	220-240/50	215	24	Water cooling	Bullet shape	Huajun	R290	464
EWBH356W-N	398x510x610	13.5	220-240/50	215	28	Water cooling	Bullet shape	Huajun	R290	270

EWBH25S
EWBH40S

- Touch operation, LED display
- Automatic ice making
- Adjustable ice thickness
- With cleaning and timing functions

Model	Product Dim (W/D/H mm)	Net capacity (L)	Voltage /Frequency (V/Hz)	Power (W)	Ice making capacity (kg/24h)	Ice shape	Compressor	Refrigerant	40 HQ Container loading
EWBH25S	380x450x700	30	220-240/50,60	300	25	Cube shape	Cubigel	R290	192
EWBH40S	380x450x700	30	220-240/50,60	320	40	Cube shape	Cubigel	R290	192



EWBH6

- Powerful, continuous cooling
- Fast, energy-saving, cost-saving, revenue-generating
- Body made of premium stainless steel
- Easy to use
- Easy to clean

Model	Product Dim (W/D/H mm)	Net capacity (L)	Voltage /Frequency (V/Hz)	Power (W)	Ice making capacity (kg/24h)	Ice shape	Compressor	Refrigerant	40 HQ Container loading
EWBH6	380x450x630	28	220-240/50	245	5	Crescent shape	GMCC	R600a	288



EWBH25

- Powerful, continuous cooling
- Body made of premium stainless steel
- With cleaning function
- With adjustment foot
- Easy to use
- Easy to clean

Model	Product Dim (W/D/H mm)	Net capacity (L)	Voltage /Frequency (V/Hz)	Power (W)	Ice making capacity (kg/24h)	Ice shape	Compressor	Refrigerant	40 HQ Container loading
EWBH25	350x532x686	30	220-240/50	160	25	Crescent shape	Cubigel	R290	234

ICE MAKER

- Adjust the ice thickness by digital
- Scheduled appointment for startup
- Body made by stainless steel and strengthen industrial grade plastics
- With cleaning function



EWBH160
EWBH230

Model	Product Dim (W/D/H mm)	Net capacity (L)	Voltage /Frequency (V/Hz)	Power (W)	Ice making capacity (kg/24h)	Cooling system	Ice shape	Compressor	Refrigerant	40 HQ Container loading
EWBH160	570x840x1660	270	230/50	1100	160	Ventilated	Cube shape	Secop	R290	38
EWBH230	770x840x1720	540	230/50	1350	230	Ventilated	Cube shape	Secop	R290	28

WINE COOLER

- With activated carbon filter to eliminate odor and remove excessive humidity in the air
- Optional for one or two cooling compartments in one door
- Smart touch temperature control
- With digital temperature display
- High quality temperature sensor
- High capacity with many layers
- Beech wooden shelves
- With lock and key
- LED light
- With recessed handle



WKM100S-1N WKM100S-2N WKM120S-1N WKM120S-2N WKM160S-1N WKM160S-2N WKM200S-1N WKM200S-2N

Model	Product Dim (W/D/H mm)	Net capacity (L)	Voltage /Frequency (V/Hz)	Power (W)	Cooling system	Temp(°C)	Shelves No.	Compressor	Refrigerant	40 HQ Container loading
WKM100S-1N	395x580x840	94	220-240/50	90	Ventilated	5~18	8	Jiaxipera	R600a	180
WKM100S-2N	395x580x840	89	220-240/50	90	Ventilated	5~10 10~18	7	Jiaxipera	R600a	180
WKM120S-1N	495x580x840	120	220-240/50	90	Ventilated	5~18	8	Jiaxipera	R600a	144
WKM120S-2N	495x580x840	108	220-240/50	90	Ventilated	5~10 10~18	7	Jiaxipera	R600a	144
WKM160S-1N	395x580x1275	155	220-240/50	90	Ventilated	5~18	12	Jiaxipera	R600a	90
WKM160S-2N	395x580x1275	139	220-240/50	90	Ventilated	5~10 10~18	11	Jiaxipera	R600a	90
WKM200S-1N	495x580x1275	200	220-240/50	90	Ventilated	5~18	12	Jiaxipera	R600a	72
WKM200S-2N	495x580x1275	192	220-240/50	90	Ventilated	5~10 10~18	11	Jiaxipera	R600a	72

PROFESSIONAL REFRIGERATION

WINE COOLER

- With activated carbon filter to eliminate odor and remove excessive humidity in the air
- Optional for one or two cooling compartments in one door
- Smart touch temperature control
- With digital temperature display
- High quality temperature sensor
- High capacity with many layers
- With beech wooden shelves
- With lock and key
- LED light
- With pull handle



WKM100ES-1N

WKM100ES-2N

WKM120ES-1N

WKM120ES-2N

WKM160ES-1N

WKM160ES-2N

WKM200ES-1N

WKM200ES-2N

Model	Product Dim (W/D/H mm)	Net capacity (L)	Voltage /Frequency (V/Hz)	Power (W)	Cooling system	Temp(°C)	Shelves No.	Compressor	Refrigerant	40 HQ Container loading
WKM100ES-1N	395x580x840	94	220-240/50	90	Ventilated	5~18	7	Jiaxipera	R600a	180
WKM100ES-2N	395x580x840	89	220-240/50	90	Ventilated	5~10 10~18	7	Jiaxipera	R600a	180
WKM120ES-1N	495x580x840	120	220-240/50	90	Ventilated	5~18	7	Jiaxipera	R600a	144
WKM120ES-2N	495x580x840	108	220-240/50	90	Ventilated	5~10 10~18	7	Jiaxipera	R600a	144
WKM160ES-1N	395x580x1275	155	220-240/50	90	Ventilated	5~18	12	Jiaxipera	R600a	90
WKM160ES-2N	395x580x1275	139	220-240/50	90	Ventilated	5~10 10~18	11	Jiaxipera	R600a	90
WKM200ES-1N	495x580x1275	200	220-240/50	90	Ventilated	5~18	12	Jiaxipera	R600a	72
WKM200ES-2N	495x580x1275	192	220-240/50	90	Ventilated	5~10 10~18	11	Jiaxipera	R600a	72

WINE COOLER

- With activated carbon filter to eliminate odor and remove excessive humidity in the air
- Optional for one or two cooling compartments in one door
- Smart touch temperature control
- With digital temperature display
- High quality temperature sensor
- High capacity with many layers
- With beech wooden shelves
- With lock and key
- LED light
- Optional for recessed handle or pull handle

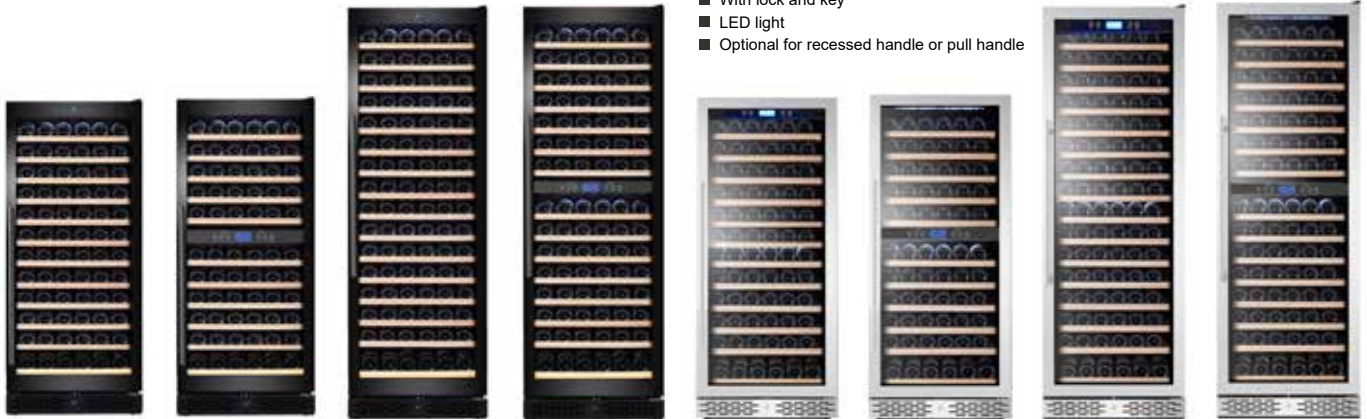

WKM350S-1N WKM350S-2N WKM450S-1N WKM450S-2N WKM350ES-1N WKM350ES-2N WKM450ES-1N WKM450ES-2N

Model	Product Dim (W/D/H mm)	Net capacity (L)	Voltage /Frequency (V/Hz)	Power (W)	Cooling system	Temp(°C)	Shelves No.	Compressor	Refrigerant	40 HQ Container loading
WKM350S-1N	595x680x1397	320	220-240/50	180	Ventilated	5~18	12	Jiaxipera	R600a	51
WKM350S-2N	595x680x1397	306	220-240/50	180	Ventilated	5~10 10~18	11	Jiaxipera	R600a	51
WKM450S-1N	595x680x1769	425	220-240/50	180	Ventilated	5~18	16	Jiaxipera	R600a	51
WKM450S-2N	595x680x1769	410	220-240/50	180	Ventilated	5~10 10~18	15	Jiaxipera	R600a	51
WKM350ES-1N	595x680x1397	320	220-240/50	180	Ventilated	5~18	12	Jiaxipera	R600a	51
WKM350ES-2N	595x680x1397	306	220-240/50	180	Ventilated	5~10 10~18	11	Jiaxipera	R600a	51
WKM450ES-1N	595x680x1769	425	220-240/50	180	Ventilated	5~18	16	Jiaxipera	R600a	51
WKM450ES-2N	595x680x1769	410	220-240/50	180	Ventilated	5~10 10~18	15	Jiaxipera	R600a	51



WKNR400N

- Cooling system on top
- 4 sides with triple glazing
- Digital control
- For up to 81 wine bottles
- Ventilated cooling system
- Adjustable shelves
- Automatic defrost

Model	Product Dim (W/D/H mm)	Net capacity (L)	Voltage /Frequency (V/Hz)	Power (W)	Cooling system	Temp(°C)	Shelves No.	Compressor	Refrigerant	40 HQ Container loading
WKNR400N	656x656x1892	400	220-240/50	500	Ventilated	2~8	9	Embraco	R290	45

PROFESSIONAL REFRIGERATION

TOP CURVED SLIDING LID CHEST FREEZER



TTS335N



TTS445N

- Defrost water drain hole
- Environmentally friendly
- New style curved sliding glass lid
- Aluminum door frame
- Adjustable thermostat
- Four caster wheels

Model	Product Dim (W/D/H mm)	Net capacity (L)	Voltage /Frequency (V/Hz)	Power (W)	Cooling system	Temp(°C)	Baskets No.	Compressor	Digital thermostat	Refrigerant	40 HQ Container loading
TTS335N	1270x680x850	355	220-240/50	210	Static	-15~-25	4	Zanussi	XMT	R290	50
TTS445N	1530x680x850	445	220-240/50	248	Static	-15~-25	5	Zanussi	XMT	R290	44

TOP FLAT SLIDING LID CHEST FREEZER



TTSA107AN

- Defrost water drain hole
- Adjustable feet
- Environmentally friendly
- Easily open from front or back side

Model	Product Dim (W/D/H mm)	Net capacity (L)	Voltage /Frequency (V/Hz)	Power (W)	Cooling system	Temp(°C)	Baskets No.	Compressor	Digital thermostat	Refrigerant	40 HQ Container loading
TTSA107AN	585x525x840	97	220-240/50	58	Static	-15~-25	1	Qianjiang	XMT	R600a	228

SOLID LID CHEST FREEZER



TTS97A+N

- Defrost water drain hole
- Adjustable feet
- Environmentally friendly
- Suitable for wide climate
- Adjustable thermostat
- Recessed handle on front side

Model	Product Dim (W/D/H mm)	Net capacity (L)	Voltage /Frequency (V/Hz)	Power (W)	Cooling system	Temp(°C)	Baskets No.	Compressor	Digital thermostat	Refrigerant	40 HQ Container loading
TTS97A+N	580x560x840	97	220-240/50	45	Static	-25~ 0	1	LG	XMT	R600a	223



TTS468A+N

Model	Product Dim (W/D/H mm)	Net capacity (L)	Voltage /Frequency (V/Hz)	Power (W)	Cooling system	Temp(°C)	Baskets No.	Compressor	Digital thermostat	Refrigerant	40 HQ Container loading
TTSA305A+N	1030x755x840	269	220-240/50	64	Static	-25~ 0	1	LG	XMT	R600a	64
TTS368A+N	1270x755x840	354	220-240/50	69	Static	-25~ 0	1	LG	XMT	R600a	54
TTS468A+N	1530x755x840	439	220-240/50	71	Static	-25~ 0	2	LG	XMT	R600a	44
TTS554A+N	1810x755x840	537	220-240/50	98	Static	-25~ 0	2	Danfu	XMT	R600a	36



TTS450A+N

Model	Product Dim (W/D/H mm)	Net capacity (L)	Voltage /Frequency (V/Hz)	Power (W)	Cooling system	Temp(°C)	Baskets No.	Compressor	Digital thermostat	Refrigerant	40 HQ Container loading
TTS272A+N	1030x755x840	269	220-240/50	64	Static	-25~ 0	1	LG	XMT	R600a	64
TTS358A+N	1270x755x840	354	220-240/50	69	Static	-25~ 0	1	LG	XMT	R600a	54
TTS450A+N	1530x755x840	439	220-240/50	71	Static	-25~ 0	2	LG	XMT	R600a	44

PROFESSIONAL REFRIGERATION

ICE CREAM MACHINE

- Three different flavours
- Possibility to mix two flavours
- Two funnels of 10 litres
- Electronic control panel with LCD display
- With digital temperature display
- Warning for low filling level
- Standby function
- For ice cream, custard and sorbet
- Easy to clean



SEMB40N

Model	Product Dim (W/D/H mm)	Ice making capacity (L/h)	Voltage /Frequency (V/Hz)	Power (W)	Cooling system	Compressor	Refrigerant	40 HQ Container loading
SEMB40N	540x720x1400	26-30	220-240/50,60	2100	Air cooling	Cubigel	R290	57

- Tabletop device
- Electronic control with digital touch display
- Standby function
- With Silent motor
- Easy to clean



SEMG16K



SEMG32K

- Tabletop device
- Electronic control with digital touch display
- Standby function
- With Silent motor
- Easy to clean
- Independent control
- Three different flavours

Model	Product Dim (W/D/H mm)	Ice making capacity (L/h)	Voltage /Frequency (V/Hz)	Power (W)	Compressor	Refrigerant	40 HQ Container loading
SEMG16K	210x660x740	16-18	220-240/50	1250	Embraco	R290	321
SEMG32K	400x760x785	30-32	220-240/50	2900	Embraco	R290	168

- Integrated transparent hopper structure
- Oversize stainless steel water tank
- Full automatic discharge system
- Oversize frozen cylinder to increase the production by 30%
- Extension-type rotated scraper make ice cream taste smooth
- Innovated one-button unfreezing
- Digital display
- Easy to use



EMG14
EMG18



EMB20

- Highly-efficient heating exchanging cylinders for fast production
- Electricity consumption saving
- Intelligence LCD control to show ingredient and temperature
- With high current warning and motor protection
- Masterly blender design
- Easy to use

Model	Product Dim (W/D/H mm)	Ice making capacity (L/24h)	Voltage /Frequency (V/Hz)	Power (W)	Cooling system	Compressor	Refrigerant	40 HQ Container loading
EMG14	502x656x802	10-14	220-240/50	1040	Air cooling	Embraco	R290	116
EMG18	502x656x802	16-20	220-240/50	1250	Air cooling	Embraco	R290	116
EMB20	550x1030x1320	26-30	220-240/50	2800	Air cooling	Embraco	R290	40

- Tabletop device
- Put liquid material directly into machine, and no need to freeze in advance
- Optional for soft ice cream and hard ice cream
- Digital display
- Compact and space-saving
- With removable containers
- Elegant design
- Easy to clean



EMH15

Model	Product Dim (W/D/H mm)	Net capacity (L)	Voltage /Frequency (V/Hz)	Power (W)	Temp(°C)	Compressor	Refrigerant	40 HQ Container loading
EMH15	241x390x326	1.5	220-240/50	140	-20	Huayi	R600a	1540

TABLE ICE SHOWCASE

- Optimal product display
- Made of high quality stainless steel
- Digital temperature controller and display
- Automatic Defrost
- Adjustable feet



EAVNR67



EAVNR87N



VDNR763



VDNR1043

Model	Product Dim (W/D/H mm)	Net capacity (L)	Voltage /Frequency (V/Hz)	Power (W)	Cooling system	Temp(°C)	Compressor	Refrigerant	40 HQ Container loading
EAVNR67	805x666x356	67	220-240/50	220	Static	-18~-25	Cubigel	R290	252
EAVNR87N	867x735x373	87	220-240/50	210	Static	-18~-25	Cubigel	R290	130
VDNR763	767x612x328	67	220-240/50	105	Static	2~12	Donper	R600a	258
VDNR1043	1035x477x328	67	220-240/50	105	Static	2~12	Donper	R600a	252

ICE-CREAM CART

- Suitable for packaged and unpacked ice cream
- Convenient to move with wheels between different vending place
- With lifting canopy, can be installed at will
- Novel design and eye-catching, can attract more customers
- With multi-functional storage box
- Can be personally customized



SPEWRHA12



SPEWEHA12



SPEWHA3



SPEWF6-LED

Model	Product Dim (W/D/H mm)	Net capacity (L)	Voltage /Frequency (V/Hz)	Power (W)	Cooling system	Temp(°C)	Compressor	Digital thermostat	Refrigerant	40 HQ Container loading
SPEWRHA12	2146x1011x2435	107	220-240/50	1034	Ventilated	-16~-18	Secop	Elitech	R290	10
SPEWEHA12	2146x1011x2435	107	220-240/50	1034	Ventilated	-16~-18	Secop	Elitech	R290	10
SPEWHA3	1570x862x2276	256	220-240/50	210	Static	-16~-18	Cubigel	Carel	R290	13
SPEWF6-LED	2665x950x2600	256	220-240/50	210	Static	-16~-18	Cubigel	Carel	R290	22

PROFESSIONAL REFRIGERATION

ICE-CREAM SHOWCASE

- European fashionable style ice cream showcase
- Double layer glass, electrically heated, with good anti condensation and insulation effect
- Glass front, optional for curved and flat shape
- Two sliding windows
- Automatic defrost
- Easy to clean
- LED light



ETHA1711W



ETHA1711S



ETHA1710W



ETHA1710S

- European fashionable style table ice cream showcase
- LED light inside, good display effect
- Compact and space-saving
- The door can be paused at any angle when opening it
- Heatable pane
- Automatic defrost
- Easy to clean



TEVHA2W



TEVHA2S



TEVHA3W



TEVHA3S



TEVHA67W



TEVHA67S

Model	Product Dim (W/D/H mm)	Net capacity (L)	Voltage /Frequency (V/Hz)	Power (W)	Cooling system	Temp(°C)	Compressor	Digital thermostat	Refrigerant	40 HQ Container loading
ETHA1711W	1728x1125x1350	247.5	220-240/50	1452	Ventilated	-16~-18	Embraco	Elitech	R290	9
ETHA1711S	1728x1125x1350	247.5	220-240/50	1452	Ventilated	-16~-18	Embraco	Elitech	R290	9
ETHA1710W	1728x1095x1300	226	220-240/50	1452	Ventilated	-16~-18	Embraco	Elitech	R290	9
ETHA1710S	1728x1095x1300	226	220-240/50	1452	Ventilated	-16~-18	Embraco	Elitech	R290	9
TEVHA2W	465x750x360	32.4	220-240/50	175	Static	-16~-18	Wanbao	Dixell	R290	290
TEVHA2S	465x750x360	32.4	220-240/50	175	Static	-16~-18	Wanbao	Dixell	R290	290
TEVHA3W	670x750x360	55	220-240/50	178.5	Static	-16~-18	Wanbao	Dixell	R290	168
TEVHA3S	670x750x360	55	220-240/50	178.5	Static	-16~-18	Wanbao	Dixell	R290	168
TEVHA67W	670x750x360	55	220-240/50	178.5	Static	-16~-18	Wanbao	Dixell	R290	168
TEVHA67S	670x750x360	55	220-240/50	178.5	Static	-16~-18	Wanbao	Dixell	R290	168

BEER COOLER WITH TAP

- With refrigeration system
- Temperature is adjustable
- Optional for stainless steel or corrosion resistant vinyl on steel for exterior construction
- Installation board is removable to access condenser coil for cleaning and service
- Adjustable feet or caster wheels with brakes
- With adjustable heavy-duty PVC coated shelves
- Self-closing doors
- With lock and key



BKZG579N



BKZG1269N



BKZG1869N

Model	Product Dim (W/D/H mm)	Net capacity (L)	Voltage /Frequency (V/Hz)	Power (W)	Cooling system	Temp(°C)	Compressor	Digital thermostat	Refrigerant	40 HQ Container loading
BKZG579N	596x772x1308	186	220-240/50	160	Ventilated	0 ~ 5	Embraco	Dixell	R290	84
BKZG1269N	1240x620x1308	335	220-240/50	223	Ventilated	0 ~ 5	Embraco	Dixell	R290	54
BKZG1869N	1848x620x1308	556	220-240/50	320	Ventilated	0 ~ 5	Embraco	Dixell	R290	36

SLUSH MACHINE



SMNC12S



SMNC24S



SMNC36S



SMNC6S

- Coated stainless steel body
- Food-grade PC tank material
- Side panel handle design
- Convenient to move
- High temperature resistance
- Non-toxic and environment friendly
- Ice consistency adjustable
- With drain tray
- Easy to clean

Model	Product Dim (W/D/H mm)	Net capacity (L)	Voltage /Frequency (V/Hz)	Power (W)	Cooling system	Temp(°C)	Compressor	Refrigerant	40 HQ Container loading
SMNC12S	270x510x810	12	220-240/50,60	400	Air cooling	-2~-10	Huayi	R290	264
SMNC24S	470x510x810	24	220-240/50,60	880	Air cooling	-2~-10	Huayi	R290	168
SMNC36S	670x510x810	36	220-240/50,60	1150	Air cooling	-2~-10	Cubigel	R290	126
SMNC6S	350x500x520	6	220-240/50,60	430	Air cooling	-2~-7	Wanbao	R290	444

PROFESSIONAL REFRIGERATION

JUICE DISPENSER

- For cooling beverages
- Coated stainless steel body
- Food-grade PC tank material
- Integrated stirrer blade
- Powerful compressor
- With drain tray
- Easy to clean
- Built-in carrying handle



ASSN50S



SSNC18S



SSNC36S



SSNC54S



SSNC20S



SSNC30S



SSNC40S

Model	Product Dim (W/D/H mm)	Net capacity (L)	Voltage /Frequency (V/Hz)	Power (W)	Cooling system	Temp(°C)	Compressor	Refrigerant	40 HQ Container loading
ASSN50S	398x353x680	50	220-240/50.60	400	Air cooling	7~12	Wanbao	R290	264
SSNC18S	345x445x700	18	220-240/50.60	290	Air cooling	7~12	Wanbao	R290	494
SSNC36S	460x445x700	36	220-240/50.60	600	Air cooling	7~12	Wanbao	R290	300
SSNC54S	710x445x700	54	220-240/50.60	700	Air cooling	7~12	Wanbao	R290	224
SSNC20S	320x445x680	20	220-240/50.60	350	Air cooling	7~12	Wanbao	R290	494
SSNC30S	450x445x680	30	220-240/50.60	600	Air cooling	7~12	Wanbao	R290	360
SSNC40S	590x445x680	40	220-240/50.60	500	Air cooling	7~12	Wanbao	R290	284

- Body made by S/S
- Two optional ice buckets inside the PC bucket, one with holes and the other one without
- Simple operation
- With non-slip feet
- Cooled by ice cubes



SSH751



ESSH751



SSH752



SSH753

Model	Product Dim (W/D/H mm)	Net capacity (L)	40 HQ Container loading
SSH751	277x347x563	7.5	756
ESSH751	279x352x533	7.5	756
SSH752	577x347x563	15	368
SSH753	876x347x563	22.5	264

JUICE DISPENSER

- Removable lid
- Cooled by ice cubes
- Modern design
- Elegant and robust
- Easy to clean
- High quality stainless steel



SSY8



SSY2S

Model	Product Dim (W/D/H mm)	Net Capacity(L)	40 HQ Container loading
SSY8	260x350x580	8	1176
SSY2S	540x350x580	16	588

BEER TOWER

- Deal for beer, mixed drinks or even non-alcoholic beverages
- Slim and spectacular drinking column for parties
- Keeps drinks cool & carbonated with ice cubes inside
- Tap for self-service

BSH15S
BSH3S

Model	Product Dim (W/D/H mm)	Net capacity (L)	Material	40 HQ Container loading
BSH15S	Dia.170x490	1.5	PP	2579
BSH3S	Dia.170x820	3	PP	1808

MILK REFRIGERATOR WITH CUP WARMER

- Digital temperature controller
- Touch panel operation and digital display
- Independent selection of internal light control
- Hidden handle glass door
- Reserved hole for straw of milk shake machine
- Tempered glass and stainless steel



MKNR15



Model	Product Dim (W/D/H mm)	Net capacity (L)	Voltage /Frequency (V/Hz)	Power (W)	Cooling system	Temp(°C)	Compressor	Refrigerant	40 HQ Container loading
MKNR15	300X525X640	15	220-240/50	300	Static	2~8	Meizhi	R600a	114

COOKING EQUIPMENT



- Electric deep fryer
- Electric griddle
- Gas stove
- Electric stove
- Chip heating
- Neutral element-with drawer
- Gas lava rock grill
- Bain marie
- Substructure
- Electric griddle
- Industrial toaster
- 9 slice toaster
- Waffle maker
- Cone maker
- Salamander
- Toaster
- Fryer
- Automatic donut machine
- Tree striezel machine
- Takoyaki machine
- Egg tart machine
- Pasta cooker
- Induction cooker
- China wok for open kitchen
- Gas cooker
- Microwave oven
- Pizza oven
- Steam oven
- Speed oven
- Hot air circulating electric oven
- Slice toaster
- Egg boiler
- Rice cooker
- Crepes device
- Sous vide
- Sous vide cooker
- Bain marie
- Bain marie thermal trolley
- Electric hamburger machines
- Hot dog grill
- Hot dog maker
- Hot dog display case
- Cotton candy machine
- Popcorn machine
- Trolley for popcorn machine
- Chocolate fountain
- Hot chocolate dispenser
- Chocolate melting machine
- Chip warmer
- Cheese warmer
- Stainless steel sauce dispenser
- Sausage warmer
- Thermal bridge
- Fries warmers
- Heat retaining plate
- Cooling plate for gn pan
- Stainless steel food warmer
- Heat lamp
- Heated display case
- Food steam showcase
- Plate warmer
- Cup warmer
- Food dehydrator
- Banquet trolley
- Top bain marie with glass lid
- Bain marie hotpot
- Chafing dish
- Soup warmer
- Soup kettle
- Coffee percolator
- Water boiler
- Coffee machine
- Coffee station
- Hot drinks dispenser
- Warming plate
- Glass icer with led lighting
- Smoker house



ELECTRIC DEEP FRYER

- Good quality heater, quick temperature rising, and energy-efficient
- HL+SB stainless steel, delicate in appearance
- EGO thermostat. Intelligent temperature control of high precision to make sure the food taste
- Stainless steel and nickel-plated fryer basket is good enough for frying food
- Temperature limiter can make the fryer safe when the thermostat out of control



EFK46-EN
EFK400-EN



EFK66-EN
EFK800-EN



EFK473H-10N



EFK873H-10+10N



EFFE600-E
EFFE700-E



EFFE773

600 series

Model	Product Dim (W/D/H mm)	Net capacity (L)	Voltage /Frequency (V/Hz)	Power (W)	Temp (°C)	40 HQ Container loading
EFK46-EN	400x600x420	10	380-415/50	9000	50~190	288
EFK66-EN	600x600x420	10x2	380-415/50	18000	50~190	204
EFFE600-E	600x630x420	23	380-415/50	15000	30~190	200

700 series

Model	Product Dim (W/D/H mm)	Net capacity (L)	Voltage /Frequency (V/Hz)	Power (W)	Temp (°C)	40 HQ Container loading
EFK400-EN	400x700x420	10	380-415/50	9000	50~190	248
EFK800-EN	800x700x420	10x2	380-415/50	18000	50~190	112
EFK473H-10N	400x700x420	10	380-415/50	9000	50~190	248
EFK873H-10+10N	800x700x420	10x2	380-415/50	18000	50~190	112
EFFE700-E	700x700x420	23	380-415/50	15000	30~190	221
EFFE773	700x700x420	23	380-415/50	15000	30~190	221

ELECTRIC GRIDDLE

- Extra-thick griddle, smooth surface, without welding spot, even heat transmission.
- HL+SB stainless steel, delicate in appearance.
- EGO thermostat. Intelligent temperature control of high precision.
- The drop pan like the drawing, it is easy to take out.



EBK46-E



EBGK46-E



EBK66-E



EBGK66-E

600 series

Model	Product Dim (W/D/H mm)	Voltage /Frequency (V/Hz)	Power (W)	Temp (°C)	40 HQ Container loading
EBK46-E	400x600x420	380-415/50	4500	50~300	288
EBGK46-E	400x600x420	380-415/50	4500	50~300	288
EBK66-E	600x600x420	380-415/50	9000	50~300	204
EBGK66-E	600x600x420	380-415/50	9000	50~300	204



EBK400-E



EBGK400-E



EBK800-E



EBGK800-E



EGK473M



EGK473MG



EGK873M



EGK873MGG

700 series

Model	Product Dim (W/D/H mm)	Voltage /Frequency (V/Hz)	Power (W)	Temp (°C)	40 HQ Container loading
EBK400-E	400x700x425	380-415/50	3600	50~300	248
EBGK400-E	400x700x425	380-415/50	3600	50~300	248
EBK800-E	800x700x425	380-415/50	7100	50~300	112
EBGK800-E	800x700x425	380-415/50	7100	50~300	112
EGK473M	400x700x425	380-415/50	3600	50~300	248
EGK473MG	400x700x425	380-415/50	3600	50~300	248
EGK873M	800x700x425	380-415/50	7100	50~300	112
EGK873MGG	800x700x425	380-415/50	7100	50~300	112

GAS STOVE

- High quality burner, more energy-efficient.
- It features convenient installation, safe use.
- HL+SB stainless steel, delicate in appearance.
- Special design of the grate, high temperature resistance.



GHK46-E



GHK66-E



GHK126-E

600 series

Model	Product Dim (W/D/H mm)	Electrical Power or gas power	Power (W)	Gas Type	Burner Qty	40 HQ Container loading
GHK46-E	400x600x420	Gas Power	6800	NG	2	288
GHK66-E	600x600x420	Gas Power	1360	NG	4	204
GHK126-E	1200x600x420	Gas Power	2040	NG	6	104

COOKING EQUIPMENT

GAS STOVE

- High quality burner, more energy-efficient.
- It features convenient installation, safe use.
- HL+SB stainless steel, delicate in appearance.
- Special design of the grate, high temperature resistance.



GHK400-E



GHK800-E



GHK1200-E



GHK473M



GHK873M



GHK173M

700 series

Model	Product Dim (W/D/H mm)	Electrical Power or gas power	Power (W)	Gas Type	Burner Qty	40 HQ Container loading
GHK400-E	400x700x420	Gas Power	11000	NG	2	248
GHK800-E	800x700x420	Gas Power	25000	NG	4	112
GHK1200-E	1200x700x420	Gas Power	39000	NG	6	92
GHK473M	400x700x420	Gas Power	11000	NG	2	248
GHK873M	800x700x420	Gas Power	25000	NG	4	112
GHK173M	1200x700x420	Gas Power	39000	NG	6	92

ELECTRIC STOVE

- HL+SB stainless steel, delicate in appearance.
- EGO hot plate, even heat transmission, more durable.
- Three-way switch, every hot plate is controlled independently.
- Hi-limit to make sure safe use.



EHK400-E



EHK800-E



EHK46-E



EHK66-E



EHK473E



EHK873E

600 series

Model	Product Dim (W/D/H mm)	Voltage /Frequency (V/Hz)	Power (W)	Temp (°C)	40 HQ Container loading
EHK46-E	400x600x420	380-415/50	4000	50~400	288
EHK66-E	600x600x420	380-415/50	8000	50~400	204

700 series

Model	Product Dim (W/D/H mm)	Voltage /Frequency (V/Hz)	Power (W)	Temp (°C)	40 HQ Container loading
EHK400-E	400x700x425	380-415/50	4600	50~400	248
EHK800-E	800x700x425	380-415/50	9200	50~400	112
EHK473E	400x700x425	380-415/50	4600	50~400	248
EHK873E	800x700x425	380-415/50	9200	50~400	112

CHIP HEATING

- Produced in line with the hygiene and safety directives.
- Meets CE standards
- Can be combined with products in the "Mario 700" range
- Top and bottom heat freely adjustable.
- Easy handling,easy to clean.



FWK46-E



FWK400-EN



WK473

600 series

Model	Product Dim (W/D/H mm)	Pans Qty	Voltage /Frequency (V/Hz)	Power (W)	Temp (°C)	40 HQ Container loading
FWK46-E	400x600x540	1/1 GN Pan	220-240/50	1170	30~110	216

700 series

Model	Product Dim (W/D/H mm)	Pans Qty	Voltage /Frequency (V/Hz)	Power (W)	Temp (°C)	40 HQ Container loading
FWK400-EN	400x700x540	1/1 GN Pan	220-240/50	1170	30~110	186
WK473	400x700x540	1/1 GN Pan	220-240/50	1170	30~110	186

NEUTRAL ELEMENT-WITH DRAWER

- HL+SB stainless steel ,delicate in appearance.
- It can be used alone,or tied with 700 series cooking range.



NEK46-E
NEK400-E



NK473S

600 series

Model	Product Dim (W/D/H mm)	40 HQ Container loading
NEK46-E	400x600x420	288

700 series

Model	Product Dim (W/D/H mm)	40 HQ Container loading
NK473S	400x700x420	248
NEK400-E	400x700x420	248



COOKING EQUIPMENT

GAS LAVA ROCK GRILL

- Quick temperature rising, and heating evenly.
- Intelligent temperature control of high precision to make sure the foods taste.
- Detachable grate, easy to clean.
- Increase the drop pan, easy to clean.
- HL+SB stainless steel, delicate in appearance.



GLGK400-E



GLGK800-E



GLGK46-E



GLGK66-E



GLK473C



GLK873C

600 series

Model	Product Dim (W/D/H mm)	Electrical Power or gas power	Power (W)	Gas Type	Burner Qty	40 HQ Container loading
GLGK46-E	400x600x420	Gas power	5300	NG	1	288
GLGK66-E	600x600x420	Gas power	10600	NG	2	204

700 series

Model	Product Dim (W/D/H mm)	Electrical Power or gas power	Power (W)	Gas Type	Burner Qty	40 HQ Container loading
GLGK400-E	400x700x420	Gas power	7000	NG	1	248
GLGK800-E	800x700x420	Gas power	14000	NG	2	112
GLK473C	400x700x420	Gas power	7000	NG	1	248
GLK873C	800x700x420	Gas power	14000	NG	2	112

BAIN MARIE

- Good quality heater, quick temperature rising, and heating evenly.
- HL+SB stainless steel, delicate in appearance.
- EGO thermostat, intelligent temperature control of high precision.

BMK46-E
BMK400-EBMK66-E
BMK800-E

EBK473C



EBK873C

600 series

Model	Product Dim (W/D/H mm)	Pans Qty	Voltage /Frequency (V/Hz)	Power (W)	Temp (°C)	40 HQ Container loading
BMK46-E	400x600x420	1xGN1/1 or 3xGN1/3	220-240/50	1200	30~85	288
BMK66-E	600x600x420	1xGN1/1 or 3xGN1/3	220-240/50	1200	30~85	204

700 series

Model	Product Dim (W/D/H mm)	Pans Qty	Voltage /Frequency (V/Hz)	Power (W)	Temp (°C)	40 HQ Container loading
BMK400-E	400x700x425	1xGN1/1 or 2xGN1/2	220-240/50	1200	30~85	248
BMK800-E	800x700x425	2xGN1/1 or 4xGN1/2	220-240/50	2400	30~85	112
EBK473C	400x700x425	1xGN1/1 or 2xGN1/2	220-240/50	1200	30~85	248
EBK873C	800x700x425	2xGN1/1 or 4xGN1/2	220-240/50	2400	30~85	112

SUBSTRUCTURE



GK466T



GK866T



GK126T



GK166T



UBK400-E
UBK46-E



UBK800-E
UBK66-E



UBK1200-E
UBK126-E



UBK1600-E
UBK166-E

- Can be combined with products in the 700 series range.
- Highest standard of workmanship
- Material is wash-resistant and can withstand alkali solutions.
- Adjustable stainless steel feet (to 50 mm height-adjustable).



SS2K466



SS2K466-E

Model	Product Dim (W/D/H mm)	Door Qty	40 HQ Container loading
GK466T	400x660x587	1	390
GK866T	800x660x587	2	210
GK126T	1200x660x587	3	130
GK166T	1600x660x587	4	120
UBK400-E	400x660x587	1	390
UBK800-E	800x660x587	2	210
UBK1200-E	1200x660x587	3	130
UBK1600-E	1600x660x587	4	120
UBK46-E	400x560x587	1	475
UBK66-E	600x560x587	2	266
UBK126-E	1200x560x587	3	140
UBK166-E	1600x560x587	4	135
SS2K466	400x660x587	/	390
SS2K466-E	400x660x587	/	390

COOKING EQUIPMENT

ELECTRIC GRIDDLE



EGKB353



- Extra-thick griddle, smooth surface, without welding spot, even heat transmission.
- Good quality stainless steel, delicate in appearance.
- EGO thermostat. Intelligent temperature control of high precision.
- The drop pan like the drawing, it is easy to take out.

Model	Product Dim (W/D/H mm)	Voltage /Frequency (V/Hz)	Power (W)	Temp (°C)	40 HQ Container loading
EGKB353	260x500x270	220-240/50	1600	50~300	720



EGK55



EGK75

- Extra-thick griddle, smooth surface, without welding spot, even heat transmission.
- Good quality stainless steel, delicate in appearance.
- EGO thermostat. Intelligent temperature control of high precision.
- Flat plate, including power regulator, Grease capture drawer, Easy to clean

Model	Product Dim (W/D/H mm)	Voltage /Frequency (V/Hz)	Power (W)	Temp (°C)	40 HQ Container loading
EGK55	550x450x230	220-240/50	3000	50~300	480
EGK75	730x500x230	220-240/50	4300	50~300	360

INDUSTRIAL TOASTER

- Contact grill
- Grill plates top & bottom, grooved
- Perfectly suited to professional use
- Adjustable thermostat
- Timer function
- Temperature: From 50°C to 300°C
- Operating light(s)
- Highly space-saving
- Easy to clean



DKGJ432



DKGJ322



DKGJ542

Model	Product Dim (W/D/H mm)	Voltage /Frequency (V/Hz)	Power (W)	Temp (°C)	40 HQ Container loading
DKGJ432	310x410x210	220-240/50	1800	50~300	672
DKGJ322	435x410x210	220-240/50	2200	50~300	672
DKGJ542	570x410x210	220-240/50	1800+1800	50~300	336

- Contact grill
- Grill plates top & bottom, grooved
- Panini dimensions
- Temperature: 50 °C to 300 °C
- Perfectly suited to professional use
- Heat-resistant handle
- Perfect ergonomic formation
- Adjustable thermostat
- On/off switch
- Operation control lights
- Highly space-saving
- Easy to clean
- Cast iron grill area with enamelled surface
- Grooved surface



KGJ432



KGJ442



KGJ542

Model	Product Dim (W/D/H mm)	Voltage /Frequency (V/Hz)	Power (W)	Temp (°C)	40 HQ Container loading
KGJ432	310x410x210	230/50	1800	50~300	672
KGJ442	435x410x210	230/50	2200	50~300	672
KGJ542	570x410x210	230/50	1800+1800	50~300	336

- Plastic handle to make sure chef safe use.
- EGO thermostat, Temperature: From 50°C to 300°C. Intelligent temperature control of high precision.
- Highly space-saving.
- All sides are grilled simultaneously.
- Convenient installation, safe use, even heat transmission, waterproof, damp proof, long life and substantial price.



KGKB100



KGKB200



KGKB300

Model	Product Dim (W/D/H mm)	Voltage /Frequency (V/Hz)	Power (W)	Temp (°C)	40 HQ Container loading
KGKB100	310x310x200	220-240/50	2200	50~300	1200
KGKB200	430x310x200	220-240/50	2800	50~300	960
KGKB300	570x310x200	220-240/50	4400	50~300	630

9 SLICE TOASTER

- Contact grill
- Grill smooth at top & bottom
- Perfectly suited to professional use
- Adjustable thermostat
- Operating light(s)
- Highly space-saving
- Body made of premium stainless steel
- Flat surface
- Cast iron grill area
- All sides are grilled simultaneously



KGJ12

KGJ13

Model	Product Dim (W/D/H mm)	Voltage /Frequency (V/Hz)	Power (W)	Temp (°C)	40 HQ Container loading
KGJ12	355x490x280	230/50	2200	50~300	588
KGJ13	355x490x280	230/50	2200	50~300	588

COOKING EQUIPMENT

9 SLICE TOASTER



KGGEJ432



KGGLJ432

- Top & bottom, grooved
- Perfectly suited to professional use
- Heat-resistant handle
- Perfect ergonomic formation
- Very simple manual operation
- Operation control lights
- Cast Aluminum grill area
- Housing made of stainless steel

Model	Product Dim (W/D/H mm)	Voltage /Frequency (V/Hz)	Power (W)	Temp (°C)	40 HQ Container loading
KGGEJ432	355x490x250	230/50	2200	50~300	672
KGGLJ432	355x490x250	230/50	2200	50~300	672

- Good quality heater, quick temperature rising, and heating evenly.
- HL+SB stainless steel, delicate in appearance.
- EGO thermostat, intelligent temperature control of high precision.



WEKB-BE



WEKB-BD



WEKB-E



WEKB100



WEKB200

Model	Product Dim (W/D/H mm)	Voltage /Frequency (V/Hz)	Power (W)	Temp (°C)	40 HQ Container loading
WEKB-BE	450x350x300	220-240/50	2000	50~300	630
WEKB-BD	850x350x300	220-240/50	4000	50~300	360
WEKB-E	450x350x300	220-240/50	2000	50~300	630
WEKB100	280x400x290	220-240/50	1200	50~300	775
WEKB200	560x400x290	220-240/50	2400	50~300	500

WAFFLE MAKER

- Outstanding for professional use
- Premium quality
- Waffle diameter: 18 cm
- Operation control lights
- Durable device
- Simple operation
- Fast and efficient heat distribution



WEJ180



WETJ180



WERJ180



WDJ180

Model	Product Dim (W/D/H mm)	Voltage /Frequency (V/Hz)	Power (W)	Temp (°C)	40 HQ Container loading
WEJ180	250x490x300	230/50	1300	50~300	756
WETJ180	250x490x300	230/50	1300	50~300	756
WERJ180	250x390x260	230/50	1300	50~300	1008
WDJ180	500x390x260	230/50	1300+1300	50~300	672

WAFFLE MAKER

- Double waffle iron
- Outstanding for professional use
- 2 baking sheet, heart-shaped
- Premium quality
- For 2 waffles
- On / off switch
- Operation control lights
- Durable device
- Simple operation



MELJ322N

Model	Product Dim (W/D/H mm)	Voltage /Frequency (V/Hz)	Power (W)	Temp (°C)	40 HQ Container loading
MELJ322N	500x390x260	230/50	1300+1300	50 ~300	588

- Outstanding for professional use
- Premium quality
- Operation control lights
- Durable device
- Simple operation
- Fast and efficient heat distribution



WAEHJ1



WAEEJ1



WAEBJ1



WAEBJ2

- Outstanding for professional use
- Premium quality
- Operation control lights
- Durable device
- Simple operation
- Easy to clean
- fast and efficient heat distribution (Heating up and down) The baking pan is made of iron, the surface is treated with enamel

Model	Product Dim (W/D/H mm)	Voltage /Frequency (V/Hz)	Power (W)	Temp (°C)	40 HQ Container loading
WAEHJ1	250x390x260	230/50	1.3	50~300	1008
WAEEJ1	310x400x230	230/50	1.75	50~300	882
WAEBJ1	310x400x240	230/50	2	50~300	1064
WAEBJ2	590x400x240	230/50	2+2	50~300	560

CONE MAKER

- Outstanding for professional use
- Premium quality
- Ice cream skin diameter:210mm
- Operation control lights
- Durable device
- Simple operation
- Easy to clean
- Fast and efficient heat distribution, The baking pan is made of aluminum, and the surface is treated with Teflon non-stick layer



WAEEHJ1



WAEEHJ2

Model	Product Dim (W/D/H mm)	Voltage /Frequency (V/Hz)	Power (W)	Temp (°C)	40 HQ Container loading
WAEEHJ1	250x390x260	230/50	1300	50~300	1008
WAEEHJ2	500x390x260	230/50	1300+1300	50~300	672

COOKING EQUIPMENT

SALAMANDER

- Quick temperature rising, and heating evenly.
- Convenient installation, safe use.
- High quality stainless steel handle to make sure safe use.
- Body made of premium stainless steel.



SKB80



SKB58

Model	Product Dim (W/D/H mm)	Voltage /Frequency (V/Hz)	Power (W)	Temp (°C)	40 HQ Container loading
SKB80	800x450x470	220-240/50	3600	30~250	325
SKB58	580x390x390	220-240/50	2200	30~250	360



SMK55



SMK65

- Uniform heating machine spring system
- With adjustable Top
- Stainless steel baking net
- EGO Proportions
- Bakelite handle high temperature resistance
- Aluminum plated back cover



SMK64E1

- Efficient heat
- With 15Min timer
- EGO Proportions
- Stainless steel baking net

Model	Product Dim (W/D/H mm)	Voltage /Frequency (V/Hz)	Power (W)	Temp (°C)	40 HQ Container loading
SMK55	450x510x525	220-240/50-60	2800	50~300	328
SMK65	600x510x525	220-240/50-60	4000	50~300	240
SMK64E1	610x340x280	220-240/50-60	2000	50~300	680

- Quartz Tube
- With 15Min Timer
- Efficient cooking time and uniform heat distribution



SMK1700



SMK3000

Model	Product Dim (W/D/H mm)	Voltage /Frequency (V/Hz)	Power (W)	Temp (°C)	40 HQ Container loading
SMK1700	440x300x290	230/50	1700	≤238	720
SMK3000	440x300x400	230/50	3000	95≤Upper, Unders143	480



SMJ30



SMJ30D



SMJ64

- Essential for buffets and catering
- Separately adjustable thermostats
- Operation control lights
- Freely detachable stainless steel shelf
- Compact and space saving
- Simple operation
- Operation control lights
- Housing made of stainless steel

Model	Product Dim (W/D/H mm)	Voltage /Frequency (V/Hz)	Power (W)	Temp (°C)	40 HQ Container loading
SMJ30	440x300x290	230/50	2400	50~300	882
SMJ30D	440x300x405	230/50	3600	50~300	630
SMJ64	485x350x300	230/50	2000	50~300	882

SALAMANDER

- Made by S/S
- Element can be vertically moved for different cooking models
- Removable grid and drip tray for easy cleaning
- Table mounted or wall mounted type available



SMH45



SMH65

Model	Product Dim (W/D/H mm)	Voltage /Frequency (V/Hz)	Power (W)	Temp (°C)	40 HQ Container loading
SMH45	450X491X507	220-240/50,60	2800	<240	328
SMH65	650X503X507	220-240/50,60	4600	<240	228

TOASTER

- Essential for buffets and catering
- Two separately adjustable thermostats
- Operation control lights
- On/off switch
- 2 Heating zones
- Compact and space saving
- Simple operation
- Easy to clean
- Housing made of stainless steel



TJ535



TJ543

Model	Product Dim (W/D/H mm)	Voltage /Frequency (V/Hz)	Power (W)	Temp (°C)	40 HQ Container loading
TJ535	350x510x350	220-240/ 50,60	1300	50 ~300	520
TJ543	430x510x350	220-240/ 50,60	2200	50~300	440

- Adjustable conveyor speed.
- Easy to clean, simple operation.
- Black plastic foot to make the products have exquisite appearance.
- Good quality heater, quick temperature rising, and heating evenly.



DTKB200



DTKB300

Model	Product Dim (W/D/H mm)	Voltage /Frequency (V/Hz)	Power (W)	Temp (°C)	40 HQ Container loading
DTKB200	368x418x400	220-240/50	2300	30~300	750
DTKB300	468x418x400	220-240/50	2600	30~300	600

COOKING EQUIPMENT

FRYER-WITH DRAIN COCK

- Good quality heater, quick temperature rising, and heating evenly.
- Good quality stainless steel, delicate in appearance.
- Angelopo thermostat. Intelligent temperature control of high precision.
- Production is long-lasting and good healthy for chef.



EFK653-8



EFK653-8+8

Model	Product Dim (W/D/H mm)	Net capacity (L)	Voltage /Frequency (V/Hz)	Power (W)	Temp (°C)	40 HQ Container loading
EFK653-8	360x650x (330+80)	12-14	380-400/ 50,60	4500	30~190	500
EFK653-8+8	600x650x (330+80)	(12-14)x2	380-400/ 50,60	4500x2	30~190	300

ELECTRIC FRYER

- Good quality heater, quick temperature rising, and heating evenly.
- Good quality stainless steel, delicate in appearance.
- EGO thermostat. Intelligent temperature control of high precision.



EFK343-8



EFK344-12

Model	Product Dim (W/D/H mm)	Net capacity (L)	Voltage /Frequency (V/Hz)	Power (W)	Temp (°C)	40 HQ Container loading
EFK343-8	260x410x370	8	220-240/50,60	3250	30~190	1200
EFK344-12	290x440x410	12	220-240/50,60	2800	30~190	875

- Good quality heater, quick temperature rising, and heating evenly.
- Good quality stainless steel, delicate in appearance.
- EGO thermostat. Intelligent temperature control of high precision.



EFK643-8+8



EFK644-12+12

Model	Product Dim (W/D/H mm)	Net capacity (L)	Voltage /Frequency (V/Hz)	Power (W)	Temp (°C)	40 HQ Container loading
EFK643-8+8	550x410x370	8x2	220-240/50,60	3250x2	30~190	600
EFK644-12+12	580x440x410	12x2	220-240/50,60	2800x2	30~190	400

- Good quality heater, quick temperature rising, and heating evenly.
- Good quality stainless steel, delicate in appearance.
- EGO thermostat. Intelligent temperature control of high precision.



EFJ-30



Model	Product Dim (W/D/H mm)	Net capacity (L)	Voltage /Frequency (V/Hz)	Power (W)	Temp (°C)	40 HQ Container loading
EFJ-30	550x470x386	31	400 3N/50,60	5000	50~200	420

ELECTRIC FRYER



- Body made by stainless steel
- anti-corrosion is not rust and easy to clean.
- Safety measures such as anti-scalding handles,
- non-slip feet, and waterproof switches ensure safe use.



EFH4



EFH4+4



EFH8



EFH8+8

Model	Product Dim (W/D/H mm)	Net capacity (L)	Voltage /Frequency (V/Hz)	Power (W)	Temp (°C)	40 HQ Container loading
EFH4	264x548x306	3.5-4	230/50	2500	≤185	1056
EFH4+4	494x548x306	3.5x2-4x2	230/50	2500x2	≤185	624
EFH8	313x568x386	6-8	230/50	3250	≤185	680
EFH8+8	598x568x386	6x2-8x2	230/50	3250x2	≤185	400

- Optimal heat distribution
- Rubber feet for secure the stability
- Made of premium stainless steel
- Removable lid
- Water drain valve
- Easy to use



EFMH8



EFMH8+8



Model	Product Dim (W/D/H mm)	Net capacity (L)	Voltage /Frequency (V/Hz)	Power (W)	Temp (°C)	40 HQ Container loading
EFMH8	638x295x427	8	230/50	3250	≤185	390
EFMH8+8	638x594x427	2x8	230/50	2x3250	≤185	200

INDUCTION DEEP FAT FRYER

- Efficient heat transfer
- Stainless steel housing for easy cleaning
- Overheating Protection
- With adjustable feet
- Temperature rang from 60°C- 190°C

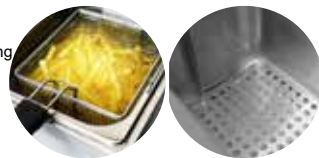

IFBZ8



IFBZ8+8

Model	Product Dim (L/W/H mm)	Net capacity (L)	Voltage /Frequency (V/Hz)	Power (W)	Temp (°C)	40 HQ Container loading
IFBZ8	288x478x410	8	220-240/50-60	3500	60~190	456
IFBZ8+8	576x478x410	8+8	220-240/50-60	3500+3500	60~190	152

COOKING EQUIPMENT

ELECTRIC HIGH-PRESSURE FRYER

- High pressure deep fat fryer
- Manual control panel
- For frying vegetables, fruit, meat and fish
- Frying in a vacuum saves oil and energy
- Maximum temperature: 200 °C
- Per cooking: 4 - 5 whole chickens
- stand-alone unit
- With 1 sink
- Capacity: max. 24 L
- Outstanding for professional use
- Compact and robust construction
- Safety lock
- 4 Roller with parking brakes
- Easy to clean



EHFMY491



EHFMY535

Model	Product Dim (W/D/H mm)	Net capacity (L)	Voltage /Frequency (V/Hz)	Power (W)	Temp (°C)	40 HQ Container loading
EHFMY491	460x960x1230	24	380 3N/50	12000	<200	90
EHFMY535	380x530x470	16	220-240/50	3000	<200	460

- High pressure deep fat fryer
- Digital control panel
- Automatic oil cleaning system with special filter with oil pump
- Various programmes
- For frying vegetables, fruit, meat and fish
- Frying in a vacuum saves oil and energy
- Maximum temperature: 200 °C
- Per cooking: 4 - 5 whole chickens
- stand-alone unit
- With 1 sink
- Capacity: max. 25 L
- Outstanding for professional use
- Compact and robust construction
- Safety lock
- 4 Roller with parking brakes
- Easy to clean



EHFDY491



Model	Product Dim (W/D/H mm)	Net capacity (L)	Voltage /Frequency (V/Hz)	Power (W)	Temp (°C)	40 HQ Container loading
EHFDY491	460x960x1230	25	380/50	13500	<200	90

- The computer control panel, elegant, easy to operate.
- High efficiency heating elements.
- Shortcuts to save memory function, time constant temperature, easy to use for frying different food
- A cylinder double basket, two baskets were timed respectively
- Comes with oil filter system, not additionally oil filtration vehicle.
- Equipped with thermal insulation, save energy and improve efficiency..



EFY25N

Model	Product Dim (W/D/H mm)	Net capacity (L)	Voltage /Frequency (V/Hz)	Power (W)	Temp (°C)	40 HQ Container loading
EFY25N	441x949x1180	25	380/50	14200	<200	106

GAS FRYER

- Three burners or five burners, power is high
- The main spare parts are all imported from USA
- Robertshaw gas valve, hi-limit and thermostat are good quality
- 4 Adjustable stainless steel feet (to 50 mm height-adjustable)
- Good quality stainless steel to make the appearance looks better
- Big basket can be loaded more food



GFK481-16



GFK591-40

Model	Product Dim (W/D/H mm)	Electrical Power or gas power	Gas Type	Net capacity (L)	Power (W)	temp (°C)	40 HQ Container loading
GFK481-16	394x770x1160	Gas power	NG	16	9000x3	30~190	124
GFK591-40	545x770x1160	Gas power	NG	30	9000x5	30~190	60

AUTOMATIC DONUT MACHINE



DMANP2



DMANP4

- Professional device
- Excellently suited for use in professional kitchens
- Manufacturable donut sizes: 40-50 mm; 60-70 mm; 80-90 mm
- Body made of premium stainless steel

Model	Product Dim (W/D/H mm)	Net capacity (L)	Voltage /Frequency (V/Hz)	Power (W)	Temp (°C)	40 HQ Container loading
DMANP2	360x965x640	13	220-240/50	3000	60~200	220
DMANP4	525x620x440	4.8	220-240/50	2800	50~200	288

TREE STRIEZEL MACHINE



BSMNP16



- Professional device
- Excellently suited for use in professional kitchens
- Easy to clean
- High quality stainless steel

Model	Product Dim (W/D/H mm)	Voltage /Frequency (V/Hz)	Power (W)	Temp(°C)	40 HQ Container loading
BSMNP16	375x760x535	220-240/50	3500	50~300	317

COOKING EQUIPMENT

TAKOYAKI MACHINE



CPMJ3

- separately adjustable thermostats
- Aluminum baking tray, Teflon coated
- Simple operation
- Easy to clean
- Housing made of stainless steel

Model	Product Dim (W/D/H mm)	Voltage /Frequency (V/Hz)	Power (W)	Temp(°C)	40 HQ Container loading
CPMJ3	675X450X180	230/50	6000	50~300	378

EGG TART MACHINE



TMNP

- Excellently suited for use in professional kitchens
- Machine for baking tartelettes
- Machine is supplied without mold
- Fitting baking plates: PLTMNP13, PLTMNP38, PLTMNP36, PLTMNP9, PLTMNP14, PLTMNP12, PLTMNP15
- Digital screen
- Temperature indicator lamp
- fast and efficient heat distribution
- Body made of premium stainless steel
- Surface Teflon coated
- Stands on 4 stainless steel feet

Model	Product Dim (W/D/H mm)	Voltage /Frequency (V/Hz)	Power (W)	Temp (°C)	40 HQ Container loading
TMNP	440x470x465	220-240/50	3200	0~400	432



PLTMNP9



PLTMNP12



PLTMNP13



PLTMNP14



PLTMNP15



PLTMNP36



PLTMNP38

Model	Product Dim (W/D/H mm)	Tartlet top diameter .bottom .height (mm)	Interior&Exterior Material	NW/GW(kg)	40 HQ Container loading
PLTMNP9	380x328x50	Tartlet top:80 bottom:80 height:18	cast aluminium+Teflon	12/13	3909
PLTMNP12	380x328x50	Tartlet top:72x72 bottom:62x62 height:19	cast aluminium+Teflon	12/13	3909
PLTMNP13	380x328x50	Tartlet top :47 bottom :29 height :20	cast aluminium+Teflon	12/13	3909
PLTMNP14	380x328x50	Tartlet top:110x60 bottom:100x48 height:20	cast aluminium+Teflon	10.79/13	3909
PLTMNP15	380x328x50	Tartlet top: 90x26 bottom:85x26 height:19	cast aluminium+Teflon	12/13	3909
PLTMNP36	380x328x50	Tartlet top:37 bottom:37 height:16	cast aluminium+Teflon	12/13	3909
PLTMNP38	380x328x50	Tartlet top:49 bottom:38 height:18	cast aluminium+Teflon	11/13	3909

PASTA COOKER

- Pasta cooker
- Temperature infinitely adjustable
- Operation control lights
- Perfectly suited to professional use
- Easy handling
- Adjustable thermostat
- Simple operation
- Easy to clean



Model	Product Dim (W/D/H mm)	Voltage /Frequency (V/Hz)	Power (W)	Temp (°C)	40 HQ Container loading
NKJ4	420x580x340	230/50	3000	30~110	504
NKJ6	600x580x350	230/50	3000	30~110	504

INDUCTION COOKER



IDS1



IDS2



IDS3



IDS4



IDS5



IDS6



IDS7



IDS8



IDS9

- Fast cooking
- Fault indicate
- Empty pan & overheat protection
- LED Display
- 5 exhaust fans to drop the internal temperature less than 60 °C
- Full oil sealed circuit board design provides waterproof surface and keep insects out
- Automatic shutdown without any operation after 4 hours (Except timer setting)
- EMC test, aging test, leakage test, high voltage test, mainboard test, total 5 testing
- Oil-proof and corrosion-proof power line

Model	Product Dim (W/D/H mm)	Voltage /Frequency (V/Hz)	Power (W)	Temp (°C)	40 HQ Container loading
IDS1	360x380x125	220-240/50-60	3500	< 235	1000
IDS2	400x400x125	220-240/50-60	3500	< 235	1000
IDS3	375x500x186	220-240/50-60	3500	< 235	600
IDS4	335x435x119	220-240/50-60	3500	< 235	1000
IDS5	360x460x129	220-240/50-60	3500	< 235	1000
IDS6	400x510x240	220-240/50-60	5000	< 235	560
IDS7	320x393x119	220-240/50-60	2700	< 235	1080
IDS8	375x500x186	220-240/50-60	3500	< 235	600
IDS9	400x400x190	220-240/50-60	3500	< 235	600

COOKING EQUIPMENT

INDUCTION COOKER



IDBZ2

- Portable induction hob
- Tabletop unit
- Smooth glass ceramic surface
- Energy-saving
- Temperature and time switch via sensor touch control
- Particularly suitable for canteens, bistros, catering services and buffets
- Touch-pad control panel & manual controls
- Double display
- 2 Hot plate(s), round
- Overheat protection
- Non-slip feet
- Plastic housing

Model	Product Dim (W/D/H mm)	Voltage /Frequency (V/Hz)	Power (W)	Temp (°C)	40 HQ Container loading
IDBZ2	602x360x60	220-240/50-60	3500	60~240	1821

CHINA VOK FOR OPEN KITCHEN

- PG or NG can be used
- Delicate in appearance.
- Quick temperature rising, and energy-efficient.
- Protect valve can make the fryer safe when the thermostat out of control.



MCWK460

Model	Product Dim (W/D/H mm)	Electrical Power or gas power	Gas Type	Power (W)	40 HQ Container loading
MCWK460	Ø460x330	Gas power	PG/NG	10000	532

GAS COOKER

- PG or NG can be used
- Delicate in appearance.
- Quick temperature rising, and energy-efficient.
- Protect valve can make the fryer safe when the thermostat out of control.



GKK1

Model	Product Dim (W/D/H mm)	Electrical Power or gas power	Gas Type	Power (W)	40 HQ Container loading
GKK1	500x500x510	Gas power	NG	10000	180

MICROWAVE OVEN

- Top and bottom heaters ensure faster, even heat delivery to the food, large capacity, pre-set memory, one button for common
- Three power levels and automatic fault diagnosis
- Stainless steel cavity: scratches, water corrosion and heat resistance
- Enhanced design, withstands frequent usage(hundreds of times per day)
- Smooth internal and external design, easy to clean
- Heating performance, not compromised by large capacity



MWM1718



MWM1721



MWM2510



MWM3410



MWM3414



MDM25-1000
MDM34-2100



MWM2070



MWM2010

Model	Product Dim (W/D/H mm)	Net capacity (L)	Voltage /Frequency (V/Hz)	Power (W)	40 HQ Container loading
MWM1718	420x563x340	17	230/50	1800	360
MWM1721	420x563x340	17	230/50	2100	360
MWM2510	511x432x311	25	230/50	1000	504
MDM25-1000	511x432x311	25	230/50	1000	504
MWM3410	553x485x343	34	230/50	1000	360
MWM3414	553x485x343	34	230/50	1400	360
MDM34-2100	574x528x368	34	230/50	2100	360
MWM2070	439x357x258	20	230/50	1050	1336
MWM2010	439x357x258	20	230/50	1050	1336

PIZZA OVEN

- Body made of premium stainless steel
- Fibreglass insulation
- Extremely heat-resistant
- Thermally insulated electric oven
- Interior lighting
- Easy to clean



PEKG20



PEKG20S

Model	Product Dim (W/D/H mm)	Net capacity (L)	Voltage /Frequency (V/Hz)	Power (W)	Temp (°C)	40 HQ Container loading
PEKG20	580x550x280	20	230 /50	2000	50~350	500
PEKG20S	590x570x310	27	230 /50	2000	50~350	324

- Body made of premium stainless steel
- Fibreglass insulation
- Extremely heat-resistant
- Thermally insulated electric oven
- Interior lighting
- Easy to clean



PDKG20



PDKG20S

Model	Product Dim (W/D/H mm)	Net capacity (L)	Voltage /Frequency (V/Hz)	Power (W)	Temp (°C)	40 HQ Container loading
PDKG20	585x550x430	40	230 /50	3000	50~350	288
PDKG20S	590x570x525	54	230 /50	3000	50~350	216

- Body made of premium stainless steel
- Extremely heat-resistant
- Ideal for ready made pizzas
- Heating mode: top & bottom heat
- Analog control
- Timer function up to 15 min
- Removable crumb drawer



MPOFP235



MPOFP135

Model	Product Dim (W/D/H mm)	Voltage /Frequency (V/Hz)	Power (W)	Temp (°C)	40 HQ Container loading
MPOFP235	486x358x360	230 /50	2260	50~300	400
MPOFP135	486x358x217	230 /50	1130	50~300	640

- Fast heating time: 15-20 minutes reaches the optimum operating temperature.
- Various use: compatible for pizzas, baguettes, bread, vegetables, steaks etc.
- Compact and portable design: light weight and easy to carry, perfect for use in the garden, on the balcony or camping
- Short cooking time: bake your pizzas perfectly in a very short time
- Corpus and chamber made from stainless steel



TPOGL4



TPOGL3



TPOHL3



TPOML3

Model	Product Dim (W/D/H mm)	Grill Type	Cooking area(mm)	Power (W)	Temp (°C)	Ignition	40 HQ Container loading
TPOGL4	562x720x370	16 inch Gas Pizza Oven	492x466	7500	500	Piezo ignition	440
TPOGL3	400x646x309	12 inch Gas Pizza Oven	350x305	4650	500	Piezo ignition	880
TPOHL3	400x690x309	12 inch Wood Pellet Pizza Oven	350x305	/	500	Wood pellet	880
TPOML3	400x760x309	12 inch Multi-Fuel Pizza Oven	350x305	4650	500	Piezo ignition /wood pellet	680

STEAM OVEN

- Fast and efficient heat distribution
- Speed and convenient cooking
- Applied to baking, vegetable and meat
- Comes with forced air convection to cook evenly and consistently
- Stainless steel interior and exterior for easy cleaning
- Full insulated cabinet and double pane glass door to improve the reliability and efficiency greatly



DBFP21

Model	Product Dim (W/D/H mm)	Net capacity (L)	Voltage /Frequency (V/Hz)	Power (W)	Temp (°C)	40 HQ Container loading
DBFP21	475x510x375	21	230 /50	2100	70~250	400

- Including water tank
- Steam regulator
- Timer function
- Housing made of high quality stainless steel



EHK500

Model	Product Dim (W/D/H mm)	Voltage /Frequency (V/Hz)	Power(kW)	temp (°C)	40 HQ Container loading
EHK500	550x476x380	230/50	2.5	25~200	285

SPEED OVEN

- Combination oven with impingement hot air and microwave
- Reduces cooking times by up to 80%
- Even, fast tanning
- Ideal for front cooking
- Perfect for quick preparation of snacks
- Variably adjustable fan (10-100%)
- Height-adjustable feet
- 1024 Recipes storable
- Self diagnostic system
- Energy-saving
- Integrated catalyst
- Rapid heating



EHONP17



EHONP10

- Digital control
- Capable of Storing up to 8 recipes
- External air filtration
- Stainless steel rack on top to minimize the risk of utensiles dropping
- With S/S lampblack filter, less exhaust and environment pollution
- Aluminium die-cast control panel makes it robust and durable
- Easy clean with S/S internal chamber
- Top-launched hot air impingement, lock up moisture in food
- Bottom radiant heater
- Rapid cooking, combining impingement, microwave, infrared radiance
- Color option available: black

Model	Product Dim (W/D/H mm)	Net capacity (L)	Voltage /Frequency (V/Hz)	Power (W)	Temp (°C)	40 HQ Container loading
EHONP17	460x675x660	17	230/50	3500	25~280	180
EHONP10	460x600x610	10	230/50	3300	25~280	180

COOKING EQUIPMENT

HOT AIR CIRCULATING ELECTRIC OVEN

- Modern design
- Reasonable structure,
- The operation is simple and convenient,
- Fast heating,
- Good insulation.
- The surface of the food is easy to be colored during cooking, the color is beautiful
- It can be used to cook a variety of dishes, suitable for making meat food , Can also make Western-style pastries,



EHJ300

Model	Product Dim (W/D/H mm)	Voltage /Frequency (V/Hz)	Power (W)	Temp (°C)	40 HQ Container loading
EHJ300	590x595x570	230/50	2400	300	126

SLICE TOASTER

- Essential for buffets and catering
- On/off switch
- Compact and space-saving
- Housing made of stainless steel



TOET4



TOET6

Model	Product Dim (W/D/H mm)	Product Category	Voltage /Frequency (V/Hz)	Power (W)	Temp (°C)	40 HQ Container loading
TOET4	310x270x220	4-slice Toaster	230/50	1800	110	1920
TOET6	410x270x220	6-slice Toaster	230/50	2500	110	1440

EGG BOILER



EKJ6



EKJ10

- Outstanding for professional use
- Premium quality
- With a boiled egg spoon, can boil liquid eggs
- Operation control lights
- Durable equipment
- Easy to use
- Easy to clean
- Fast and efficient heat distribution

Model	Product Dim (W/D/H mm)	Number of Egg Spoon(pcs)	Voltage /Frequency (V/Hz)	Power (W)	Temp (°C)	40 HQ Container loading
EKJ6	375x220x290	6	230/50	2200	30~110	1764
EKJ10	380x295x300	10	230/50	2600	30~110	1323

RICE COOKER



RKV16



RKF100



RKK100

- Housing made of high quality stainless steel
- Overheating protection
- Excellently suited for use in professional kitchens
- Also suitable for sushi rice

Model	Product Dim (W/D/H mm)	Net capacity (L)	Voltage /Frequency (V/Hz)	Power (W)	40 HQ Container loading
RKV16	390x390x350	8	230/50	1950	440
RKF100	455x455x370	5.4	230/50	1950	860
RKK100	548x480x410	8.2	230/50	2500	500

CREPES DEVICE



CGJ40-1



CGJ40-2



CGK40-1



CGK40-2

- pancake maker
- Quick and easy crepes
- Separately switchable plates
- Manual temperature control
- Temperature 50 - 300 °C
- Operation control lights
- Cast iron plate with teflon coating
- Made of stainless steel

- Quick temperature rising, and heating evenly.
- Convenient installation, safe use.
- High quality stainless steel handle to make sure safe use.
- Body made of premium stainless steel.

Model	Product Dim (W/D/H mm)	Voltage /Frequency (V/Hz)	Power (W)	Temp (°C)	40 HQ Container loading
CGJ40-1	450x485x240	230/50	3000	50~300	588
CGJ40-2	860x485x240	230/50	3000+3000	50~300	294
CGK40-1	450x480x235	220-240/50,60	3000	30~300	800
CGK40-2	860x485 x235	220-240/50,60	6000	30~300	416

SOUS VIDE

- LCD control setting
- Time and power display
- Water circulation system to insure the water temperature be same
- Stainless steel housing and shelf
- Drainage valves with safety locker
- Seamless stretching water tank
- Silicone seal cover



SVGVA16



SVGVA24

Model	Product Dim (W/D/H mm)	Net capacity (L)	Voltage /Frequency (V/Hz)	Power (W)	Temp (°C)	40 HQ Container loading
SVGVA16	360x450x301	16	220-240/50,60	500	30~90	528
SVGVA24	360x623x301	24	220-240/50,60	700	30~90	480

SOUS VIDE COOKER

- Easy to make food with the desired taste, color, tenderness and texture.
- It can fit into any container or pot, very good to make flavorful and high quality food.
- Error indication and low water level alarm and easy removable assembling clamp included.
- Memory function for settings
- Integrated circulation pump for a uniform temperature
- Overheat protection



SVGFP1500



SVGFW15

- With standard level to ensure machine real in waterproof quality
- Use stainless steel for whole+PC material, slim and easy control
- LED lights on the increment, easy cooperation choose temperature from 20°C-90 °C
- All material we use get approval for certification to ensure long lifetime.
- Food cooks in its juices so flavor can't escape. This ensures that the food is moist, juicy and tender.

Model	Product Dim (W/D/H mm)	Voltage /Frequency (V/Hz)	Power (W)	40 HQ Container loading
SVGFP1500	140x110x332	230 /50	1500	3000
SVGFW15	160x107x397	230/50,60	1200	8880

BAIN MARIE

- Bain marie are obtained CE ,ETL certification
- Body made by stainless steel and easy to clean
- Rubber feet for secure the stability



BMH230



BMY11150A



BMH200

Model	Product Dim (W/D/H mm)	Net capacity (L)	Voltage /Frequency (V/Hz)	Power (W)	Temp (°C)	40 HQ Container loading
BMH230	600x338x243	21	220-240/50,60	1200	≤95	720
BMH200	600x338x285	5.7	230/50	1200	≤95	720
BMY11150A	590x340x245	19	230/50	1200	≤100	1220

BAIN MARIE THERMAL TROLLEY

- High quality handle made of corrosion resistant stainless steel
- Double-walled tray for good thermal insulation
- Made of high quality stainless steel
- Water drain cock



TWK1756



TWK1758



TWK1758TD



TWK1760



TWK1760TD

Model	Product Dim (W/D/H mm)	Net capacity (L)	Voltage /Frequency (V/Hz)	Power (W)	Temp (°C)	40 HQ Container loading
TWK1756	560x650x850	26	220-240/50	900	30~90	270
TWK1758	840x650x850	20	220-240/50	1800	30~90	190
TWK1758TD	840x650x850	20x2	220-240/50	1800	30~90	190
TWK1760	1170x650x850	20x3	220-240/50	2700	30~90	135
TWK1760TD	1170x650x850	20x3	220-240/50	2700	30~90	135

ELECTRIC HAMBURGER MACHINE

- Contact grill
- Grill smooth at top & bottom
- Perfectly suited to professional use
- Specially designed for burger patties
- Adjustable thermostat
- Temperature: From 50°C to 300°C
- Operating light(s)
- Highly space-saving
- Easy to clean
- Body made of premium stainless steel
- Flat surface
- Cast iron grill area
- All sides are grilled simultaneously



HMEJ642

Model	Product Dim (W/D/H mm)	Voltage /Frequency (V/Hz)	Power (W)	Temp (°C)	40 HQ Container loading
HMEJ642	410x660x290	230/50	2200	50~300	252

HOT DOG GRILL

- Table equipment
- Simple operation
- Outstanding for professional use
- Even heat distribution
- Two separately adjustable thermostats
- Heating zones can be adjusted separately
- 2 Heating zones
- 2 Operating control lights
- On/off switch
- Easy to clean

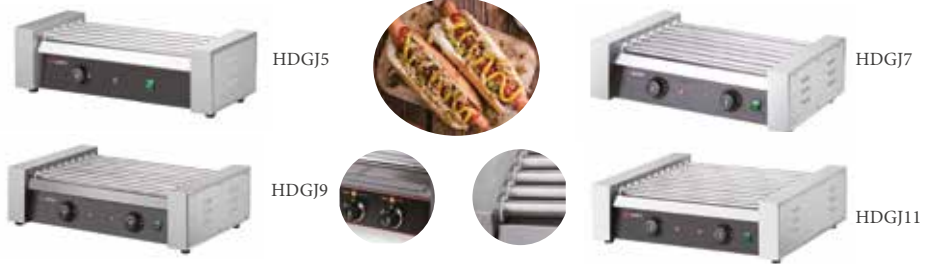

Model	Product Dim (W/D/H mm)	Voltage /Frequency (V/Hz)	Power (W)	Temp (°C)	40 HQ Container loading
HDGJ5	560x320x200	220-240/50,60	1000	50~200	1120
HDGJ7	560x385x200	220-240/50,60	1400	50~200	920
HDGJ9	560x460x200	220-240/50,60	1800	50~200	800
HDGJ11	560x530x200	220-240/50,60	2200	50~200	800

HOT DOG MAKER

- Glass cylinder height: 245 mm
- Glass cylinder diameter: Ø 200 mm
- Glass cylinder for warming and keeping sausages warm
- Removable cover
- Temperature infinitely adjustable
- Rubber feet for secure stability
- Operation control lights
- Simple operation
- Easy to clean
- Made of premium stainless steel



Model	Product Dim (W/D/H mm)	Net capacity (L)	Voltage /Frequency (V/Hz)	Power (W)	Temp (°C)	40 HQ Container loading
HDMHN	289x337x400	6.7	230/50	800	≤95	990
HDMH4N	528x337x400	6.7	230/50	1100	≤95	600

HOT DOG DISPLAY CASE

- Simple operation
- Operation control lights
- Adjustable thermostat
- Elegant presentation of goods
- Easy to clean
- Housing made of stainless steel



Model	Product Dim (W/D/H mm)	Voltage /Frequency (V/Hz)	Power (W)	Temp (°C)	40 HQ Container loading
HDVJ446	410x435x640	220-240/50,60	1200	110	378

COOKING EQUIPMENT

COTTON CANDY MACHINE

- Integrated sugar drawer with 4 separate compartments
- Non-slip feet
- Safety switch
- Adjustable thermostat
- Voltmeter indicates the voltage



ZWJ950

ZWJ950S

ZWJ950E

Model	Product Dim (W/D/H mm)	Voltage /Frequency (V/Hz)	Power (W)	Temp (°C)	40 HQ Container loading
ZWJ950 ZWJ950S ZWJ950E	520x520x485	220-240/50,60	800	50~300	336

- Safety switch
- Adjustable thermostat
- Voltmeter indicates the voltage
- Revolutions per minute: 3100 rpm
- Tub made of high quality stainless steel



ZWET52S



ZWET52

Model	Product Dim (W/D/H mm)	Voltage /Frequency (V/Hz)	Power (W)	Temp (°C)	40i HQ Container loading
ZWET52S/ZWET52	520x520x910	220-240/50,60	1080	230	320

POPCORN MACHINE

- Non-stick lined kettle and easy cleaning before cooking
- Built-in warmer light and built-in heating element beneath the deck.Keep popcorn fresh and warm for long time
- Kettle detaches for easy clean up
- Flip-up kettle lids allow popcorn to pop out of kettle.
- Machine with tempered Glass ,easy clean up and more safety
- Stainless steel fold out tray and removable ,drop the residue very convenient
- Package with contoured foam and master box.More safety during deliver



PMET5SS



PMET5SA



PMET5S2

Model	Product Dim (W/D/H mm)	Voltage /Frequency (V/Hz)	Power (W)	Temp (°C)	40 HQ Container loading
PMET5SS	560x417x770	220-240/50,60	1500	230	240
PMET5SA	900x420x760	220-240/50,60	1800	230	120
PMET5S2	900x420x760	220-240/50,60	2900	230	120

TROLLEY FOR POPCORN MACHINE

- With integrated shelf
- Suitable for PMET5S & PMET5R
- Easy to clean



WPMET



WPMETS

Model	Product Dim (W/D/H mm)	40 HQ Container loading
WPMET/WPMETS	940x500x825	320

CHOCOLATE FOUNTAIN

- Convenient and safe to operate
- Melt chocolate directly without destroying the ingredients
- Made of high quality stainless steel
- Extra-smooth cascades for improved flow

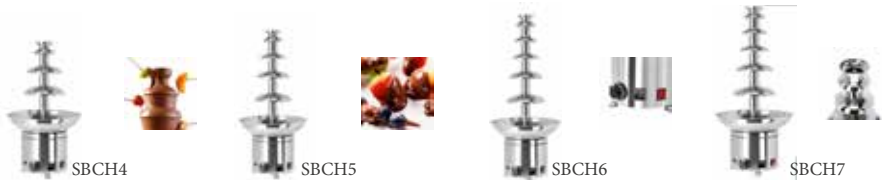

Model	Product Dim (W/D/H mm)	Net capacity (kg)	Voltage /Frequency (V/Hz)	Power (W)	Temp(°C)	40 HQ Container loading
SBCH4	Φ330x600	5	230/50,60	Heating150+ Motor80	0~110	700
SBCH5	Φ330x700	6	230/50,60	Heating200+ Motor80	0~110	700
SBCH6	Φ370x840	8	230/50,60	Heating200+ Motor100	0~150	700
SBCH7	Φ440x1000	10	230/50,60	Heating300+ Motor100	0~150	380

HOT CHOCOLATE DISPENSER

- Adjustable temperature: 0-90°C
- 120°C temperature limited
- Stir mechanism for even mixed
- Simple design for easy operation



Model	Product Dim (W/D/H mm)	Net capacity (L)	Voltage /Frequency (V/Hz)	Power (W)	Temp(°C)	40 HQ Container loading
SSK10S	410x280x580	10	220-240/50	1000	0~90	478
SSK10W	410x280x580	10	220-240/50	1000	0~90	478

CHOCOLATE MELTING MACHINE

- Suitable for GN 1/4
- With lid
- Dry heating without water both on the bottom and sides to ensure a homogeneous temperature.
- Removable stainless steel tank
- Perfect for ice cream parlors and pastry shops
- High-quality stainless steel



Model	Product Dim (W/D/H mm)	Net capacity (L)	Voltage /Frequency (V/Hz)	Power (W)	Temp(°C)	40 HQ Container loading
SCSGH14	345x285x295	3.8	220-240/50	250	30~110	1260

CHIP WARMER

- Ideal for the sales room
- Digital display
- Rubber feet for secure stability
- Simple operation
- Extremely robust
- Easy to clean
- Operation control lights
- Housing made of stainless steel



Model	Product Dim (W/D/H mm)	Voltage /Frequency (V/Hz)	Power (W)	Temp (°C)	40 HQ Container loading
NWJ55	350x350x520	220-240/50,60	300	0~85	336

COOKING EQUIPMENT

CHEESE WARMER

- Stainless steel construction
- Food grade plastic pump
- 6 Power levels
- On / off switch
- Easy to clean



KWFR

Model	Product Dim (W/D/H mm)	Net capacity (L)	Voltage /Frequency (V/Hz)	Power (W)	Temp(°C)	40 HQ Container loading
KWFR	230x388x420	4.4	230V/50	550	< 90	720

STAINLESS STEEL SAUCE DISPENSER

- Convenient to keep sauce in a certain temperature at a safe, servable liquid form.
- Hot sauces are perfect for adding value and creating intriguing flavour combinations.
- Stainless steel construction with independent simple dial control for each bottle.
- Fit 1000ml sauce bottle for each pot
- Power ON/OFF switch with non-skidding rubber feet.
- Easy to use and clean.



SSPFR2



SSPFR3

Model	Product Dim (W/D/H mm)	Net capacity (L)	Voltage /Frequency (V/Hz)	Power (W)	Temp(°C)	40 HQ Container loading
SSPFR2	270x220x205	2x1	230/50	400	40~90	1260
SSPFR3	400x220x205	3x1	230/50	600	40~90	840

SAUSAGE WARMER

- Made by premium stainless steel
- Digital thermostat
- Dry protection
- Simple operation



Model	Product Dim (W/D/H mm)	Net capacity (L)	Voltage /Frequency (V/Hz)	Power (W)	Temp(°C)	40 HQ Container loading
WWH10	270x375x265	8	230/50	1000	≤90	1400

THERMAL BRIDGE

- High-quality stainless steel.
- High-quality heating lamp, make the food keeping warm.
- Use GN pans, good quality and big volume.



WBK366-1



WBK366-2

Model	Product Dim (W/D/H mm)	Pans Qty	Voltage /Frequency (V/Hz)	Power (W)	40 HQ Container loading
WBK366-1	400x285x560	1 pcs 1/2GN pan	220-240/50,60	290	600
WBK366-2	600x330x560	1 pcs 1/1GN Pan	220-240/50,60	600	432

FRIES WARMER



SPWJ11

- Keep foods warm at constant level
- Particularly suitable for canteens, bistros, catering services and buffets
- High degree of stability
- Temperature: 0 ~ +55 °C
- Electrical heating element
- Premium workmanship
- Modern design
- Easy to clean
- The heat of this machine can be emitted from the top and bottom together

Model	Product Dim (W/D/H mm)	Voltage /Frequency (V/Hz)	Power (W)	40 HQ Container loading
SPWJ11	335 x 565 x 570	220-240/50,60	1000	672

- Safe use, even heat transmission.
- Good quality stainless steel ,delicate in appearance.
- Quartz lamp keep the chips warming.
- The lamp on the top, easy take off and clean.



BWK80

Model	Product Dim (W/D/H mm)	Voltage /Frequency (V/Hz)	Power (W)	40 HQ Container loading
BWK80	800x710x650	220-240/50,60	650	60

HEAT RETAINING PLATE

- Hot plate
- Temperature range: 0 °C to 85 °C
- Keep foods warm at constant level
- Adjustable thermostat
- Operation control lights
- Ergonomic handles
- Non-slip feet
- Easy to clean
- Made from stainless steel
- Glass surface



WHPJ537



WHPWJ756

- Hot plate
- Temperature range: 0 °C to 85 °C
- With double-sided glass sneeze guard
- Sneeze guard conducts the heat of the heat lamps directly on the food
- 2 Heat lamps
- 2 Trays
- 2 Operating control lights
- On/off switch
- Two separately adjustable thermostats
- Keep foods warm at constant level
- Non-slip feet
- Easy to clean
- Made from stainless steel
- Glass surface

Model	Product Dim (W/D/H mm)	Voltage /Frequency (V/Hz)	Power (W)	Temp(°C)	40 HQ Container loading
WHPJ537	565x380x75	220-240/50,60	260	85	1428
WHPWJ756	730x585x625	220-240/50,60	1070	85	138

COOLING PLATE FOR GN PAN

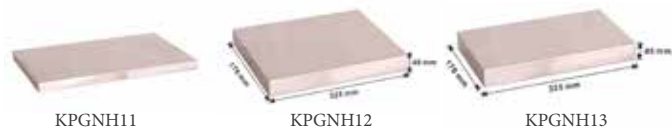

- Easy to clean
- Eco-friendly
- The cooling pockets inside keep the temperature below +8 °C for at least 4 hours after storage
- Suitable for direct contact with food or GN containers
- Ideal as a substitute for ice cubes, because the food does not get wet when thawing.
- Highly resistant and durable
- Cooling plate made of high quality stainless steel

Model	Product Dim (W/D/H mm)	40 HQ Container loading
KPGNH11	530x325x45	3480
KPGNH12	325x265x45	6873
KPGNH13	325x176x45	8700

STAINLESS STEEL FOOD WARMER



- Food warmer for keeping food warm
- Heating by solid wax which is safe for using
- Modern design
- Easy to clean
- Frame made of high gloss stainless steel

Model	Product Dim (W/D/H mm)	40 HQ Container loading
SWH2B	380x175x65	7460
SWH3B	465x175x65	6525

HEAT LAMP

- Lampshade is made of stainless steel
- The perforation on the lamps' upper section prevents an overheating
- Ideal solution for professional use
- Stylish & functional. Elegant design. Easy to clean



Model	Product Dim (W/D/H mm)		Voltage /Frequency (V/Hz)	Power (W)	40 HQ Container loading
WLH290-R	dia.290	H:600-1500	220-240/50-60	550	1920
WLH290-G	dia.290	H:600-1500	220-240/50-60	550	1920
WLH290-S	dia.290	H:600-1500	220-240/50-60	550	1920
WLH290	dia.290	H:600-1500	220-240/50-60	550	1920
WLK-S	dia.228	H:814-2114	230/50	250	2464

HEATED DISPLAY CASE

- Heating display cabinet with 3 levels
- Curved front panel
- Simple operation
- On/off switch
- Operation control lights
- Adjustable thermostat
- Elegant presentation of goods
- Easy to clean
- Housing made of stainless steel
- All sides made of glass



WHVJ3



WHVJ3N

Model	Product Dim (W/D/H mm)	Voltage /Frequency (V/Hz)	Power (W)	Temp(°C)	40 HQ Container loading
WHVJ3 WHVJ3N	355x460x475	220-240/50,60	800	85	336

FOOD STEAM SHOWCASE



KNDJ437

- 5 floor heating
- steamed food and display
- Temperature range 30-110°C
- The operation control lamp
- Adjustable thermostat controller
- Elegant display of merchandise
- Easy to clean and operate
- The case is made of stainless steel
- All sides made of glass

Model	Product Dim (W/D/H mm)	Voltage /Frequency (V/Hz)	Power (W)	Temp(°C)	40 HQ Container loading
KNDJ437	380x410x745	220-240/50,60	900	30~110	252

PLATE WARMER

- Good quality stainless steel ,delicate in appearance.
- EGO thermostat.Intelligent temperature control of high precision.
- Good quality heater,quick temperature rising,and heating evenly.



TWK60



TWK120



TWHB40



TWHB80

Model	Product Dim (W/D/H mm)	Voltage /Frequency (V/Hz)	Power (W)	Temp(°C)	40 HQ Container loading
TWK60	400x420x800	220-240/50,60	750	30~85	230
TWK120	800x420x800	220-240/50,60	1500	30~85	112
TWHB40	430x460x890	220-240/50,60	1000	30~85	275
TWHB80	430x900x890	220-240/50,60	2000	30~110	157

COOKING EQUIPMENT

CUP WARMER

- Two heating levels, One reserve shelf
- Holding capacity: ca. 80 - 120 Tassen
- Ideally suited for coffee bars and Christmas markets
- On/off switch for each heating element
- Easy to use, Easy to clean



TWJ335

Model	Product Dim (W/D/H mm)	Voltage /Frequency (V/Hz)	Power (W)	Temp(°C)	40 HQ Container loading
TWJ335	360x320x550	220-240/50,60	140	75	756

FOOD DEHYDRATOR

- Body made of premium stainless steel
- Precise - controlled process by 0 - 15 h adjustable timer
- Drying process ensures longer lasting and edible products
- Digital display
- The double shell heat insulation drying efficiency is higher and faster, and the universal wheel is convenient to move (DGHB10 has no wheel, the other three models have)
- The built-in LED light is convenient to observe the drying state at any time, and the noise is ultra-low
- Suitable for all kinds of fruits, meat, vegetables, medicinal materials, pet snacks, etc



DGHB10



DGHB16

DGHB20
DGHB24

Model	Product Dim (W/D/H mm)	Net capacity (L)	Voltage /Frequency (V/Hz)	Power (W)	Shelves No.	Temp(°C)	40 HQ Container loading
DGHB10	385x345x427	30	220-240/50,60	800	10	30~90	699
DGHB16	570x465x670	85	220-240/50,60	1500	16	30~90	255
DGHB20	570x465x820	106	220-240/50,60	2000	20	30~90	150
DGHB24	570x465x820	106	220-240/50,60	2000	24	30~90	150

- Body made of premium stainless steel
- Precise - controlled operation by 0-15 h adjustable timer
- Drying process ensures longer lasting and edible products
- Digital display
- Uniform baking by rotating design, 360° heat flow cycle to improve drying effect
- Multi-stage temperature regulation to meet different product baking requirements
- Product safety and durability by stainless steel grill mesh.
- Large capacity with many layers. A variety of ingredients can be baked
- Smart touchscreen panel for easy operation



DGH16



Model	Product Dim (W/D/H mm)	Net capacity (L)	Voltage /Frequency (V/Hz)	Power (W)	Temp(°C)	40 HQ Container loading
	545x420x750	110	220-240/50	1800	40~90	240

BANQUET TROLLEY

- Stainless steel body
- Special design for slide-out heating unit with 3.5M power line
- Microcomputer temperature control system
- Display screen clearness and directness, and simple to operate more accurate in temperature control
- With a box of humidifier to keep the food in original state
- Put rubber anti-collision stripes for 4 corners and fix handle of both sides to provide the protection during transportation



Model	Product Dim (W/D/H mm)	Pans Qty	Voltage /Frequency (V/Hz)	Power (W)	Temp(°C)	40 HQ Container loading
BWK1121	730x940x1860	GN 2/1-100MM 11PCS	220-240/50,60	2750	30~85	36
BWK2221	1540x940x1860	GN 2/1-100MM 22PCS	220-240/50,60	2750	30~85	12
BWK1511	555x740x1500	1/1 GN pans 15pcs	220-240/50,60	1050	30~85	60
BWK711	555x740x950	1/1 GN pans 7pcs	220-240/50,60	1050	30~85	120

TOP BAIN MARIE WITH GLASS LID



- Buffet and dining essential
- Automatic temperature control
- Operating light(s)
- Top with tempered glass (clean and hygienic)
- Separate food basin, can be filled with different food
- Easy to use
- Easy to clean
- Housing made of stainless steel

Model	Product Dim (W/D/H mm)	Voltage /Frequency (V/Hz)	Power (W)	Temp(°C)	40 HQ Container loading
ABMJ4	1245x350x370	220-240/50,60	1500	30~110	420
ABMJ5	1512x350x370	220-240/50,60	1800	30~110	420

BAIN MARIE HOTPOT

- Humanized coutour design, fully displays the art of delicate life
- Totally ensures the nutrition and primary taste of the delicacy
- Made by stainless steel, clean and convenient, environment friendly and sanitary



Model	Product Dim (W/D/H mm)	Net capacity (L)	Voltage /Frequency (V/Hz)	Power (W)	Temp(°C)	40 HQ Container loading
BHPV35-1	210x240x320	3.5	220-240/50,60	150	0~95	2112
BHPV65-1	255x286x320	6.5	220-240/50,60	150	0~95	1188
BHPV35-2	415x240x320	3.5x2	220-240/50,60	300	0~95	1344
BHPV65-2	505x285x320	6.5x2	220-240/50,60	400	0~95	792
BHPV35-3	610x240x320	3.5x3	220-240/50,60	450	0~95	672
BHPV35-4	415x445x320	3.5x4	220-240/50,60	600	0~95	528

COOKING EQUIPMENT

CHAFING DISH

- Graceful lines form the contour, pleasing both the eye and the mind
- The outer casing is made of high grade stainless steel, which is durable
- Large capacity, rapid heating, convenient in use



CDBV11



CDBGV11



CDEV11

Model	Product Dim (W/D/H mm)	Net capacity (L)	Voltage /Frequency (V/Hz)	Power (W)	Temp(°C)	40 HQ Container loading
CDBV11	570x360x325	13	220-240/50,60	1200	0~95	616
CDBGV11	630x360x415	13	220-240/50,60	1200	0~95	880
CDEV11	630x360x390	13	220-240/50,60	1200	0~95	880

- Perfect in workmanship with fully
- Stainless steel and easy to clean.



CDH11100E



CDH230



CDH807



CDHU11

Model	Product Dim (W/D/H mm)	Net capacity (L)	Voltage /Frequency (V/Hz)	Power (W)	40 HQ Container loading
CDH11100E	580x347x289	14	230/50	0.9	720
CDH230	629x360x298	14	230/50	1.6	720
CDH807	630x362x327	15.5	/	/	720
CDHU11	630x362x327	15.5	/	/	936

- Stainless steel housing
- Container for keeping food warm
- Modern design. Easy to clean



CDY11ID



CDY11R



CDY11



CDY55R

Model	Product Dim (W/D/H mm)	Net capacity (L)	Voltage /Frequency (V/Hz)	Power (W)	40 HQ Container loading
CDY11ID	580x440x260	8.5	230/50	420	648
CDY11R	645x475x435	8.5	/	/	510
CDY11	580x440x260	8.5	/	/	432
CDY55R	500x530x450	5	/	/	660

CHAFING DISH



CHDYK11
GCHDYK11

CHDYK55
GCHDYK55

CHDYK57
GCHDYK57

CHDYK14
GCHDYK14

- 3-layer steel bottom for fast and even heating
- Lid close & open automatically
- Lid is removable, easy for cleaning
- Tempered glass, food inside could be seen
- Hydraulic system on the lid, for smooth opening & closing
- Easy to repair the hinge for the hydraulic system
- Mirror polish for whole item
- Stainless steel for food pan

Model	Product Dim (W/D/H mm)	Net capacity (L)	40 HQ Container loading
CHDYK11	580x471x168	11.2	880
GCHDYK11	597x391x153	/	930
CHDYK55	404x472x172	5.5	930
GCHDYK55	391x421x153	/	1056
CHDYK57	455x535x170	5.7	930
GCHDYK57	516x446x175	/	1056
CHDYK14	435x475x265	14.3	1056
GCHDYK14	430x370x175	/	1056

- Keep warm at 90°C
- For use as an alternative to conventional fuel holder
- Only suitable for chafing dishes with a flat bottom
- Extremely suitable for chafing dishes without preparation for electrical elements



EHCDBZ13

Model	Product Dim (W/D/H mm)	Voltage /Frequency (V/Hz)	Power (W)	40 HQ Container loading
EHCDBZ13	Φ138x110	220-240/ 50,60	500	8424

SOUP WARMER

- Body made of premium stainless steel
- Removable stainless steel insert
- Lockable lids. Adjustable temperature
- Easy to clean



SWH57E



SWH57S

Model	Product Dim (W/D/H mm)	Net capacity (L)	Voltage /Frequency (V/Hz)	Power (W)	Maximum temp(°C)	40 HQ Container loading
SWH57E	Φ285x352	5	220-240/50,60	300	95	1365
SWH57S	Φ285x352	5	220-240/50,60	300	95	1365

COOKING EQUIPMENT

SOUP KETTLE

- Removable stainless steel insert
- Adjustable temperature
- Lockable lids



SWSH13



SWSH10

Model	Product Dim (W/D/H mm)	Net capacity (L)	Voltage /Frequency (V/Hz)	Power (W)	Maximum temp(°C)	40 HQ Container loading
SWSH13	Φ414X401	13	220-240/50	600	133	630
SWSH10	Φ341X366	9	220-240/50	400	133	1188

- Removable stainless steel insert
- Easy to clean
- Temperature infinitely adjustable
- Sealable lids
- Holding capacity: 9 Liter



SWH9S



SWH9E



SWH9R

Model	Product Dim (W/D/H mm)	Net capacity (L)	Voltage /Frequency (V/Hz)	Power (W)	Maximum temp(°C)	40 HQ Container loading
SWH9S	Φ385x366	9	220-240/50	400	95	1188
SWH9E	Φ385x366	9	220-240/50	400	95	1188
SWH9R	Φ385x366	9	220-240/50	400	95	1188

COFFEE PERCOLATOR

WATER BOILER



WKH06



WKH010



WKH015

- Level indicator
- Integrated drip tray
- Ergonomically shaped synthetic grip
- Anti-slip handle
- Stylish design
- Fast and efficient heat distribution
- Operation control lights
- With filling tap



WKH10



WKH20



WKH30

Model	Product Dim (W/D/H mm)	Net capacity (L)	Voltage /Frequency (V/Hz)	Power (W)	Maximum temp(°C)	40 HQ Container loading	Model	Product Dim (W/D/H mm)	Net capacity (L)	Voltage /Frequency (V/Hz)	Power (W)	Maximum temp(°C)	40 HQ Container loading
WKH06	378x314x429	6	220-240/50,60	1150	85	1320	WKH10	321x314x429	8	220-240,50-60	2000	100	1320
WKH010	350x344x441	10	220-240/50,60	1500	85	1080	WKH20	350x344x543	17	220-240,50-60	2500	100	864
WKH015	350x344x543	15	220-240/50,60	1500	85	1080	WKH30	440x434x427	21	220-240,50-60	3000	100	540

COFFEE MACHINE

- Modern look of stainless steel housing
- Easy access to controls on top black panel with brewing indicator
- Warming surfaces on top and/or bottom for optimal taste
- Large capacity for continuous brewing
- Double-walled flask to maintain coffee temperature



FIKAMAV17



FKMV20D



FKMV20E

Model	Product Dim (W/D/H mm)	Net capacity (L)	Voltage /Frequency (V/Hz)	Power (W)	40 HQ Container loading
FIKAMAV17	215x410x460	2.3	220-240/50-60	2000	520
FKMV20D	430x410x520	4.6	220-240/50-60	3300	520
FKMV20E	215x410x520	2.3	220-240/50-60	2000	832

- Body made of premium stainless steel
- Vacuum jug with screw cap
- Drain mechanism inside the lid
- Easy to clean



IKV20P



IKV20



KAKGV17

Model	Product Dim (W/D/H mm)	Net Capacity(L)	40 HQ Container loading
IKV20P	150x150x315	2	6240
IKV20	140x140x270	2	7488
KAKGV17	165x200x170	1.7	6240

- Made of high quality stainless steel
- The coffee machine has a high brewing life of 300,000 cups and a high quality cup
- can also achieve a one-click cup, without any coffee making experience, but also easily make a strong coffee, very simple and convenient, suitable for various scenarios



KMHB218



KMHB18



KMHB220



KMHB22

Model	Product Dim (W/D/H mm)	Net capacity (L)	Voltage /Frequency (V/Hz)	Power (W)	Temp(°C)	40 HQ Container loading
KMHB218	400x 415 x423	1.8x4	230/50,60	2020x2	93 - 96	400
KMHB18	413x 212x429	1.8x2	230/50,60	2020	93 - 96	720
KMHB220	426x201x594	2.2	230/50,60	1900	93 - 96	520
KMHB22	426x201x594	2.2	230/50,60	1900	93 - 96	520

COOKING EQUIPMENT

COFFEE STATION

- Multi-function, convenient and practical
- Drinks, snacks a taste, heart enjoy
- Suitable for all vacuum jugs up to 190 mm diameter
- 5 Storage compartments for cups, spoons/stirrers, milk and sugar
- Modern design. High quality. Easy to clean



KSV1



KSV2

Model	Product Dim (W/D/H mm)	40 HQ Container loading
KSV1	435x330x145	1716
KSV2	650x330x145	1144

HOT DRINKS DISPENSER

- Made of high quality stainless steel
- Coffee urn with stainless steel legs
- Especially used for keeping beverages warm
- Particularly suitable for canteens, bistros, catering services and buffets



HGDH5



HGDH75

Model	Product Dim (W/D/H mm)	Net Capacity(L)	40 HQ Container loading
HGDH5	312x321x539	5	1260
HGDH75	269x350x518	7.5	792

WARMING PLATE

- Graceful lines form the contour, pleasing both the eye and the mind
- The outer casing is made of high grade stainless steel, which is durable
- Large capacity, rapid heating, convenient in use
- Humanized contour design, fully displays the art of delicate life



WPV1



WPV2



WPV21

Model	Product Dim (W/D/H mm)	Voltage /Frequency (V/Hz)	Power (W)	40 HQ Container loading
WPV1	174x174x68	220-240/50,60	60	1232
WPV2	354x174x68	220-240/50,60	60x2	448
WPV2 1	180x360x250	220-240/50,60	60x2	448

GLASS ICER WITH LED LIGHTING

- Made of high quality aluminium alloy
- This glass icer brings the glasses to a temperature of up to -78.5 °C
- Sterile and hygienically perfect cooling within 7 seconds
- Works both for beverage cooling and as an impressive show object
- The latest innovation for bars and clubs with a taste for the extraordinary
- There is NO danger of burns or injuries with frozen glasses, even when drinking directly
- Suitable for all types of drinking glasses (cocktail glasses, long-drink glasses, champagne glasses, etc.)



GVS410

Model	Product Dim (W/D/H mm)	Housing color	Housing Material	Battery needed for LED	CO2 Tank Connector	40 HQ Container loading
GVS410	240x130x410	Silver	Aluminium Alloy	AA x 2	CGA320	2800

SMOKER OVEN

- Perfect for smoking vegetables, meat or fish
- For hot and warm smoking
- Temperature range: 30 °C to 120 °C
- Thermometer - easily readable on the front door
- Precise - controlled operation by 0 - 12 h adjustable timer
- 9,50 cm Space between grids
- Uncomplicated - filling or refilling the wood chips via a drawer



ROHB4



ROHB8

Model	Product Dim (W/D/H mm)	Net capacity (L)	Voltage /Frequency (V/Hz)	Power (W)	Temp(°C)	40 HQ Container loading
ROHB4	640x450x910	60	220-240/50,60	1000	30~120	168
ROHB8	640x450x1300	111	220-240/50,60	1000	30~120	84

FOOD PROCESSING EQUIPMENT



3

- Food slicer
- Vegetable slicer
- Vegetable cutter
- Potato peeler
- Potato spiral cutter
- Manual potato cutter
- Manual cutting machine
- Praline cutter
- Tomato slicer
- Kebab slicer
- Horizontal cutter
- Curry sausage slicer
- Electric meat tenderiser
- Mincing machine
- Meat mixer
- Manual meat tenderizer
- Sausage stuffer
- Bone saw
- Cake smoothing machine
- Hamburger machine
- Mixer
- Dough kneading machine
- Bakery dough sheeter
- Horizontal cutter stand
- Hand blender
- Spindle mixer
- Churro machine
- Manual donut tool
- Hopper
- Filling machine
- Electric oil press
- Juice extractor
- Food mixer
- Orange squeezer
- Vacuum machine
- Mobile glass washer
- Dish washer
- Honey extractor
- Sesame peanut butter machine
- Poultry plucker
- Poultry plucker and scalding
- Scalding kettle poultry
- Hand dryer
- Shoe polisher
- Can opener
- Juice extractor manually
- Knife sharpener
- Manual stainless steel sausage clipper
- Table ice crusher
- Food trailer



FOOD PROCESSING EQUIPMENT

FOOD SLICER



AMH220

AMH250A
AMH275A
AMH300AAMH250L
AMH275L
AMH300L

AMH350



AAMH300



AAMH320



AAMH250



AAMH320N



AAMH360



AMVH350



AMH220N

- Pure copper motor
- Adjustable thickness
- Have a sharpening stone.

Model	Product Dim (W/D/H mm)	Voltage /Frequency (V/Hz)	Power (W)	Motor Speed (r/min)	Slice Thickness (mm)	Maximum slice width (mm)	40 HQ Container loading
AMH220	425x388x329	220-240/50	120	1400	0.2-12	160	612
AMH250A	482x414x364	220-240/50	150	1400	0.2-12	180	400
AMH275A	543x462x430	220-240/50	250	1400	0.2-15	180	288
AMH300A	576x465x430	220-240/50	250	1400	0.2-15	200	288
AMH250L	482x392x375	220-240/50	150	1400	0.2-12	180	400
AMH275L	547x490x422	220-240/50	250	1400	0.2-15	180	288
AMH300L	577x491x427	220-240/50	250	1400	0.2-15	200	288
AMH350	763x629x546	220-240/50	400	1400	0.2-30	320	126
AAMH300	592x580x696	220-240/50,60	550	1400	0-15	200	162
AAMH320	747x582x764	220-240/50,60	370*2	1400	0.2-18	230	90
AAMH250	514x484x521	220-240/50,60	370	1400	0-16	185	252
AAMH320N	661x572x660	220-240/50,60	750	1400	0-16	220	153
AAMH360	1072x749x1494	220-240/50,60	750*2	1400	0-25	350	28
AMVH350	767x666x609	220-240/50	400	1400	0-30	240	90
AMH220N	416x362x339	220-240/50	120	1400	0-12	160	756

FOOD SLICER

- Pure copper motor
- Adjustable thickness
- Have a sharpening stone.



AMH220R
AMH250R
AMH300R



AMSH300



- Adjustable thickness according to requirements
- With sharpening device
- Very simple mechanical operation
- Strong and resistant

UGH300

Model	Product Dim (W/D/H mm)	Voltage /Frequency(V/Hz)	Power(W)	Motor Speed(r/min)	Slice thickness (mm)	Maximum slice width (mm)	40 HQ Container Loading
AMH220R	479x404x350	220-240/50	120	1400	0-12	160	400
AMH250R	482x414x364	220-240/50	150	1400	0-12	180	400
AMH300R	576x465x430	220-240/50	250	1400	0-15	200	288
AMSH300	716x557x563	/	/	/	0-2	250	140
UGH300	480x480x745	/	/	/	/	/	200

VEGETABLE SLICER



GEH
GEH5



GEH5R



GSH300

- Simplifies the preparation of vegetables in the kitchen
- Efficient cutting of different types of vegetables
- Ideal solution for professional use
- Silent operation
- High quality
- Space saving design
- Easy to clean

- A cutting bowl and a vegetable cutter attachment works on the same plastic motor base
- Polycarbonate lid designed to allow the addition of liquid or ingredients during processing
- Single speed 1500 rpm for two attachments
- Compact design and medium duty can meet most of daily kitchen use
- Interlocked apparatus included for safety use
- Direct drive motor
- Detachable blades and discs



GEA4



EBA5



GSA5

- Versatile and efficient: you can quickly process food to achieve different results with an excellent finish
- Utmost hygiene: the components are manufactured from materials suitable for food handling and can be easily removed for fast cleaning
- Ventilated motor: powerful and low-noise can perform all processes effortlessly
- Controls with low-voltage (24V) switch
- Discs and blades for all kinds of processing

Model	Product Dim(W/D/H mm)	Voltage /Frequency (V/Hz)	Power (W)	Motor Speed(r/min)	40 HQ Container loading
GEH	246x614x506	220-240/50,60	550	1400	712
GEH5	246x614x506	220-240/50,60	550	1400	712
GEH5R	246x614x506	220-240/50,60	550	1400	712
GSH300	268x575x528	220-240/50,60	550	1400	760
GEA4	430x285x691	220-240/50,60	735	1500	441
EBA5	289x244x260	-	-	-	2688
GSA5	570x240x540	220-240/50,60	750	1500	378

FOOD PROCESSING EQUIPMENT

VEGETABLE CUTTER



MGHH

- Desk model
- Device can be clamped to any table top by means of a screw connection
- Disc thickness: 0,3 - 8 mm
- Ideal solution for professional use
- Body made of premium stainless steel
- Efficient work possible
- Easy to clean

Model	Product Dim (W/D/H mm)	NW/GW(kg)	40 HQ Container loading
MGHH	320x280x410	3.8/4.4	900



CUH6N
CUH9N
CUH12N

- Stainless steel body and bucket
- With S-shaped blade, 10 second high-speed shredding
- Stepless speed regulation
- With non-slip feet



Model	Product Dim (W/D/H mm)	Voltage/ Frequency (V/Hz)	Power(W)	Motor Speed (r/min)	Maximum working capacity(L)	40 HQ Container loading
CUH6N	524x316x394	220-240/50,60	1800	986-2470	6	600
CUH9N	523x316x444	220-240/50,60	1800	986-2470	9	600
CUH12N	525x316x489	220-240/50,60	2000	1100-2800	12	480

POTATO PEELER

- Suitable for potatoes
- Containers with grip handles
- Safety micro switch on door and lid
- Interior walls with friction lining
- Emptying flap made of polished aluminium
- Non-slip feet made from stainless steel
- Simple operation
- Easy to clean
- Housing and containers made from stainless steel
- Transparent plastic lid



KSH300
Holding capacity:15 kg

KSH400
Holding capacity:20 kg



Model	Product Dim (W/D/H mm)	Voltage /Frequency (V/Hz)	Power (W)	Motor Speed (r/min)	Capacity(kg/h)	40 HQ Container loading
KSH300	413x586x1090	220-240/50	750	960	165	154
KSH400	465x616x1121	220-240/50	950	960	225	124

POTATO SPIRAL CUTTER

- Simple design for easy operation
- All stainless steel construction potato slicer which is designed for slicing twisted potato chips.



MKSK01

Model	Product Dim(W/D/H mm)	40 HQ Container loading
MKSK01	260x120x140	6500

MANUAL POTATO CUTTER



- Quick and easy production of wavy cut fries
- Base plate with suction pads
- Made of high quality stainless steel
- Easy to clean
- Easy to use

Model	Product Dim (W/D/H mm)	NW/GW(kg)	40 HQ Container loading
KSMNP	490X160X80	3/3.2	2640

MANUAL CUTTING MACHINE

- Suitable for coarse dicing of vegetables and fruit
- Ideal solution for professional use
- Efficient work possible
- Made of high quality stainless steel
- Easy to clean



Model	Product Dim (W/D/H mm)	Cube Thickness(mm)	NW/GW(kg)	40 HQ Container loading
SCMMNP	508x381x610	25	7.3/7.5	460
GSMHH6 GSMHH9 GSMHH12	205x205x480	6.35 9.53 12.7	2.85/3.2	1400

PRALINE CUTTER



- Praline cutter with two frames
- Perfect for pastry shops
- Excellently suited for use in professional kitchens
- Made of high quality stainless steel
- For cutting chocolates
- Easy to clean

Model	Product Dim (W/D/H mm)	Frame(mm)	Wire Spacing(mm)	NW/GW(kg)	40 HQ Container loading
PSNP20	263X670X550	200x210	28 & 14	7.52/8	1650
PSNP23	518 x 474 x 568	234 x 220	21 & 28	8.5/9	1650
PSNP28	338x537x695	280 x 275	20 & 28	24.5/25.5	900
PSNP30	629X553X695	300 x 365	23 & 89	14.5/15.5	1356
PSNP36	629X613X694	360 x 360	15, 22,5 & 30	27.5/34.5	594

FOOD PROCESSING EQUIPMENT

TOMATO SLICER

- Made of high quality stainless steel
- Ergonomic hard plastic handle
- Rubber feet for secure the stability
- Easy to clean



TSH400
TSH550



TSH100

- Body made by stainless steel
- Simple operation
- With non-slip feet

Model	Product Dim(W/D/H mm)	Slice thickness (mm)	40 HQ Container loading
TSH400	430x200x195	4	2200
TSH550	430x200x195	5.5	2200
TSH100	355X260X485	/	2520

KEBAB SLICER

- Perfect for doners, gyros, chicken doners and shoarma
- Full stainless steel blade cover
- On/off switch in the trigger position and an abrasion-resistant surface
- Lightweight plastic anti-slip body
- Adjustment ring and screw for desired thickness
- Equipped with blade protector and overload protection button



KS100C



KS100E



DSA80S



- Full stainless steel blade cover
- Adjustment ring and screw for desired thickness
- Metal anti-slip body, ergonomic design, safe and easy handling
- The front part is easily detachable for cleaning
- Wear-resistant switch
- An adapter and a slicer stand included

Model	Product Dim (W/D/H mm)	Voltage/ Frequency (V/Hz)	Power(W)	Cutting Depth(mm)	Capacity(kg/day)	Blade Dia.(mm)	40 HQ Container loading
KS100C	170x170x150	Li-ion Battery 12	80	0-8	60	Φ100	8646
KS100E	180x180x180	220-240/50	80	0-8	60	Φ100	5418
DSA80S	283x120x115	220-240/50	80	0-6	80	Φ80	5292

HORIZONTAL CUTTER



HCH8N
HCH14N



- With copper motor
- With waterproof switch
- With non-slip feet

Model	Product Dim (W/D/H mm)	Voltage/ Frequency (V/Hz)	Power(W)	Capacity(kg/h)	Motor speed (r/min)	Volume of bucket(L)	40 HQ Container loading
HCH8N	680x441x385	220-240/50-60	550	120	1450	5.5	280
HCH14N	760x515x452	220-240/50-60	750	218	1450	10	217

CURRY SAUSAGE SLICER

- Removable parts are dishwasher safe
- Disassembly of the flap within seconds
- Rotary cutter (hardened and sharpened)
- Removable Quick-Out hood lid
- Practical, maintenance-free machine
- With safety switch (forced break when the cover is removed)
- Air-cooled single phase capacitor motor (suitable for continuous operation)
- Easy to clean



CSH45N



Model	Product Dim (W/D/H mm)	Voltage /Frequency (V/Hz)	Power (W)	Motor Speed(r/min)	Slice Thickness(mm)	40 HQ Container loading
CSH45N	244x189x327	220-240/50,60	135	2650	5-30	1920



CWSH100



- Perfect in workmanship with fully stainless steel
- Evenly sliced and easy to clean
- Steady and slip-resistant
- Base plate with suction pads
- Number of sausage slices: 10 pieces
- Easy to use

Model	Product Dim (W/D/H mm)	Slice Thickness(mm)	40 HQ Container loading
CWSH100	330x189x285	18	3564

ELECTRIC MEAT TENDERISER



FKA100E



Meat Stripper Attachment
model:FKA100-1 1pc/ctn
For fresh meat slicing,Size:
24x13x12cm,Weight:4.1Kg



Tenderizer Attachment A
model:FKA100-2 1pc/ctn
For meat tenderizer,Size:
24x13x12cm,Weight:3.8Kg



Tenderizer Attachment B
model:FKA100-3 1pc/ctn
For meat tenderizer,Size:
24x13x12cm,Weight:2.9Kg

- Robust and full stainless steel model,no sharp corner
- Meets the hygiene and all safety regulations
- Simple and easy operation and cleaning
- Tenderizer,meat stripper attachments for your choice

Model	Product Dim(W/D/H mm)	Voltage /Frequency (V/Hz)	Power (W)	Capacity(kg/h)	40 HQ Container loading
FKA100E	510x250x520	230/50	350	200	710

FOOD PROCESSING EQUIPMENT

MINCING MACHINE

- Premium quality design for extreme loads
- Silent operation
- Simple operation
- Highly space-saving
- Rustproof
- Easy to clean
- Rubber feet for secure stability



FWH22
FWH85



Model	Product Dim (W/D/H mm)	Voltage /Frequency (V/Hz)	Power (W)	Capacity(kg/h)	Motor speed (r/min)	40 HQ Container loading
FWH22	493x220x397	220-240/50,60	1100	220	1450	720
FWH85	472x220x377	220-240/50,60	850	120	1450	720

- Premium quality design for extreme loads
- High-quality stainless steel
- Rubber feet for secure stability
- Simple operation
- Highly space-saving
- Rustproof
- Easy to clean



FWFC550

Model	Product Dim (W/D/H mm)	Capacity (kg/h)	Voltage /Frequency (V/Hz)	Power (W)	40 HQ Container loading
FWFC550	550x220x435	200-240	230/50	550	480

- High quality design for heavy loads
- Stainless steel meat pan with large capacity
- One fine stainless steel plate (4.5 mm)
- One coarse stainless steel plate (7 mm)
- Three stuffing tubes:15, 25 and 35mm
- With meat masher
- Space saving
- Easy to use



FWFC450



Model	Product Dim (W/D/H mm)	Capacity (kg/h)	Voltage /Frequency (V/Hz)	Power (W)	40 HQ Container loading
FWFC450	305x600x415	450-480	230/50	1000	360

- Manual operation by crank handle
- Can be upgraded at any time with FWFC450 for a motorized variant include mincer
- Knife easily removable
- Stable with rubber suction cups
- Easy to clean



FMFC25

Model	Product Dim (W/D/H mm)	Capacity (L)	40 HQ Container loading
FMFC25	570x305x550	28	360

MEAT MIXER

- High quality design for heavy loads
- Fully welded stainless steel construction
- Two perforated discs for fine and coarse meat processing
- With reverse function
- Space-saving
- Easy to clean



FWFC620
FWFC350

Model	Product Dim (W/D/H mm)	Capacity (kg/h)	Voltage /Frequency (V/Hz)	Power (W)	40 HQ Container loading
FWFC620	500x436x387	620-680	230/50	1000	368
FWFC350	479x436x387	500-550	230/50	800	368

- Bucket made by stainless steel
- With large bucket capacity
- With strong power



FMH40



FMH60



FMH80
FMH100

Model	Product Dim (W/D/H mm)	Volume of bucket(L)	Capacity(kg/h)	Voltage /Frequency (V/Hz)	Power (W)	40 HQ Container loading
FMH40	748x457x978	40	64	220-240/50,60	900	116
FMH60	850x647x988	60	96	380-415/50,60	1500	76
FMH80	1006x648x1017	80	128	380-415/50,60	2000	72
FMH100	1149x646x1014	100	160	380-415/50,60	2200	68

MANUAL MEAT TENDERIZER



MFKHB37

- Ensures a regular thickness of the meat
- The meat remains juicier and tastes better
- Perfect assistant for catering requirements
- Herbs and marinade penetrate deeper into the meat
- Easy to disassemble and clean



MFKHB27

Model	Product Dim(W/D/H mm)	Meat of max(mm)	Number of stainless steel blades	NW/GW(kg)	40 HQ Container loading
MFKHB37	330x185x290	175x25	37	6.8/7.2	882
MFKHB27	280x168x235	125x25	27	5.1/6.5	882

FOOD PROCESSING EQUIPMENT

SAUSAGE STUFFER



WFA3L
WFA5L
WFA7L



WFA3S
WFA5S
WFA7S

- Light-duty model, easy to be operated.
- Equipped with 4 different funnels, are really the best tools for stuffing any kinds of sausage
- The full stainless steel cylinder, the food approved aluminium piston with special finishing, the solid rack, the precision gears and the accurate manufacturing of all mechanical details ensure a perfect working, the maximum efficiency and long life.

Model	Product Dim(W/D/H mm)	Net capacity (L)	40 HQ Container loading
WFA3L	540×230×200	3	1512
WFA5L	570×230×200	5	1512
WFA7L	580×230×200	7	900
WFA3S	530×300×260	3	840
WFA5S	550×300×260	5	560
WFA7S	660×330×300	7	560

- Absolutely hygienic
- Very user friendly
- Protected against corrosion damages
- Water-repellent and resistant to blood, fat and oil
- Temperature resistant
- Stable beam constructionSpace-saving horizontal design
- Durable, easy-to-clean stainless steel sides and removable steel tilt-out canister
- Enclosed steel gears with 2 speed options and a heavy-duty pressure release valve ensure ultimate control over sausage consistency
- Large rubber feet and a heavy base help prevent movement during use
- Includes 16mm,22mm, 32mm and 38mm stainless steel funnels



WFMFC3L
WFMFC5L
WFMFC7L



WFMFC3
WFMFC5
WFMFC7

Model	Product Dim(W/D/H mm)	Capacity (L)	40 HQ Container loading
WFMFC3L	430×200×180	3	640
WFMFC5L	550×200×180	5	450
WFMFC7L	680×200×180	7	320
WFMFC3	380×440×540	3	1280
WFMFC5	380×430×650	5	450
WFMFC7	380×430×800	7	420

SAUSAGE STUFFER

- The model has good product mix, firm and durable, exquisite in workmanship, and provides sausage tube in different sizes, satisfy with customers' needs.
- It is easily to clean, easily to operate.
- Used widely in kitchen, restaurant and many food processing place.



WFMJ7S

Model	Product Dim(W/D/H mm)	40 HQ Container loading
WFMJ7S	785x304x304	610



EWFMH10
EWFMH12
EWFMH15

- Foot pedal operation: Free hands at work for maximum flexibility.
- Easy cleaning: The removable filling cylinder ensures easy cleaning.
- The side walls, made of high-quality solid material, provide exceptional stability and ensure that the cylinder is held securely even under heavy use.
- Very stable design (suitable for salami production)
- Operation by the foot pedal or automatic feed
- Filling speed adjustable
- By pressing a button, the cylinder can be moved up automatically



Model	Product Dim(W/D/H mm)	Capacity (L)	Voltage /Frequency (V/Hz)	Power (W)	Motor speed(r/min)	40 HQ Container loading
EWFMH10	370x330x637	10	220-240/50-60	180	1350	650
EWFMH12	370x330x667	12	220-240/50-60	180	1350	600
EWFMH15	370x330x767	15	220-240/50-60	180	1350	550

- Strict with the hygeian standard, stainless steel body.
- Big capacity of cylinder.
- Hydradulic system lifting sausage up and down. low noise and high efficiency.
- Branded electric appliance and hydraulic components ensure good quality and long service life.
- Conversion switch and foot-switch for safety operation.
- Movable body ensure greater applicability.
- Slide-hang hydraulic bag ensure easy loading, unloading .



WFMHB15
WFMHB26
WFMHB35

Model	Product Dim(W/D/H mm)	Voltage /Frequency (V/Hz)	Power (W)	Capacity(kg/h)	40 HQ Container loading
WFMHB15	600x400x1240	220-240/50	750	300	220
WFMHB26	640x485x1240	220-240/50	1100	400	180
WFMHB35	735x560x1240	220-240/50	1500	600	143

FOOD PROCESSING EQUIPMENT

BONE SAW



Bone saw 1660mm
Max cutting height: 238mm

KSH1650N



Bone saw 1660mm
Max cutting height: 245mm

KSH1650AN



Bone saw 1908mm
Max cutting height: 240mm

KSH1900



Bone saw 2020mm
Max cutting height: 304mm

KSH2020N



Bone saw 2400mm
Max cutting height: 355mm

KSH2400N

- With copper motor
- With sharp saw blade
- With waterproof switch
- With non-slip feet
- Safety feed

Model	Product Dim (W/D/H mm)	Voltage /Frequency (V/Hz)	Power (W)	Table length / width(mm)	40 HQ Container loading
KSH1650N	468x465x876	220-240/50,60	750	440/465	174
KSH1650AN	468x465x876	220-240/50,60	750	440/465	174
KSH1900	565x531x1011	220-240/50,60	750	542/531	114
KSH2020N	596x674x1585	220-240/50,60	1500	565/668	76
KSH2400N	801x743x1732	220-240/50,60	2200	767/738	48

CAKE SMOOTHING MACHINE



TGMH

- Machine for smoothing cakes and pies
- Suitable for pastry stores, dessert stores, grocery stores, households and more
- Made of high quality stainless steel and aluminum alloy
- Rotation (left + right) adjustable
- Diameter turntable: 360 mm
- Cake size and height adjustable
- Easy to clean
- Wear and corrosion resistant
- Large and stable turntable

Model	Product Dim (W/D/H mm)	Voltage /Frequency (V/Hz)	Power (W)	Capacity (r/min)	40 HQ Container loading
TGMH	410x550x580	220-240/50,60	60	40-180	278

HAMBURGER MACHINE

- Patty thickness: 15 – 18 mm
- Manual operation
- Easy to clean
- Simple operation



HMH100
HMH130
HMH150



Model	Product Dim(W/D/H mm)	Meat weight per time(g)	40 HQ Container loading
HMH100	290x210x275	99.5	2816
HMH130	290x210x275	168	2816
HMH150	295x210x275	224	1512

MIXER



Model	Product Dim (W/D/H mm)	Voltage /Frequency (V/Hz)	Power (W)	Capacity(L)	Weight (Kg)	40 HQ Container loading
RMF7B-G	236x409x421	220-240/50,60	350	7	16	560
RMF7B-P	236x409x421	220-240/50,60	350	7	16	560
RMF7B-R	236x409x421	220-240/50,60	350	7	16	560
RMF7B-GR	236x409x421	220-240/50,60	350	7	16	560
RMF7B-Y	236x409x421	220-240/50,60	350	7	16	560
RMF7B-W	236x409x421	220-240/50,60	350	7	16	560
RMF7B-G2	236x409x421	220-240/50,60	350	7	16	560
RMF7B-GG	236x409x421	220-240/50,60	350	7	16	560
RMF7B-MW	236x409x421	220-240/50,60	350	7	16	560
RMF7B-SM	236x409x421	220-240/50,60	350	7	16	560

- Low noise
- Electric machinery over-load protection
- Stepless timing
- Big power and high efficiency



RMS7



RMH7-W

- With copper motor
- With stainless steel bucket
- With non-slip feet

Model	Product Dim (W/D/H mm)	Voltage /Frequency (V/Hz)	Power (W)	Capacity (L)	40 HQ Container loading
RMS7	380x240x405	220-240/50,60	500	7	865
RMH7-W	410x205x395	230/50	800	7	1152

FOOD PROCESSING EQUIPMENT

PLANETARY MIXER

- 7 litre stainless steel bowl
- Integrated safety guard
- Secure bowl locking mechanism



RTK7N

PRMTH5
PRMTH7

- Suitable for butter, cream, eggs, creams etc.
- With hinged agitator
- The stirring tools are height adjustable
- Stainless steel kettle with handle (removable)
- Practical and versatile to use
- Easy to clean

Model	Product Dim (W/D/H mm)	Capacity(L)	Voltage /Frequency (V/Hz)	Power (W)	40 HQ Container loading
RTK7N	410x230x430	7	220-240/50	325	890
PRMTH5	351x231x412	5	230/50	300	935
PRMTH7	427x250x422	7	230/50	300	935

PRMH10
PRMH20
PRMH30

- Can mix any kind of stuffing with three kinds of beater.
- It adopts planetary mixing principle, painted cast iron body, stainless steel material which come into contact with food.
- Snake-shaped beater/Chequer-shaped beater/ Bud-shaped beater, Different kinds of stuffing used different beater.
- Different speed for your choose.
- Kneading arm, central column and bowl are made of stainless steel, according to applicable sanitary standards.
- Overload and phase-lacking protection.

PRMSH10
PRMSH20
PRMSH30

- Gear system, motor overload protection.
- High quality Schneider appliance switches included.
- The automotive spray painting avoids fading for years.
- The tin bronze gear maintains good wear-resistance.
- The pure copper motor provides stable performance, high torque and low noise.
- The premium grease seal ensures seamless sealing and prevents oil leakage.
- Cover opening protection and Bowl Sliding protection ensure the operator's safety.
- The non-welding brushed stainless steel bowl adopts one-step molding technique and enhances durability.

Model	Product Dim (W/D/H mm)	Voltage /Frequency (V/Hz)	Power (W)	Maximum dough capacity (kg)	Mixing Speed(r/min)	40 HQ Container loading
PRMH10	450x366x606	220-240/50,60	450	1.5	110/178/390	288
PRMH20	520x420x760	220-240/50,60	750	4.5	105/180/408	222
PRMH30	545x440x882	220-240/50,60	1100	5.25	105/180/408	150
PRMSH10	452x372x606	220-240/50,60	450	3	110/178/355	288
PRMSH20	530x440x780	220-240/50,60	1100	6	104/187/365	222
PRMSH30	546x440x852	220-240/50,60	1100	6	104/187/365	150

PLRM35H
PLRM40H
PLRM60H

- Belt system, motor overload protection.
- High quality Schneider appliance switches included.
- The automotive spray painting avoids fading for years.
- The tin bronze gear maintains good wear-resistance.
- The pure copper motor provides stable performance, high torque and low noise.
- The premium grease seal ensures seamless sealing and prevents oil leakage.
- Cover opening protection and Bowl Sliding protection ensure the operator's safety.
- The non-welding brushed stainless steel bowl adopts one-step molding technique and enhances durability.

Model	Product Dim (W/D/H mm)	Voltage /Frequency (V/Hz)	Power (W)	Maximum dough capacity (kg)	Mixing Speed(r/min)	40 HQ Container loading
PLRM35H	630x562x1011	220-240/50,60	1125	6.75	80/160/388	150
PLRM40H	645x562x1011	220-240/50,60	1312	9	80/160/388	150
PLRM60H	770x625x1250	380/50	2250	12	74/155/388	43

DOUGH KNEADING MACHINE

- Equipped with a microswitch controller for safety
- Heavy duty: Actual flour weight is the maximum kneading capacity
- High-efficiency
- Mixers and bowl revolves simultaneously to provide speed and better results
- Comes with safety covers
- Stainless steel bowl



STMF60



Model	Product Dim (W/D/H mm)	Voltage/ Frequency (V/Hz)	Power of the spiral motor(W)	Power of the bowl motor(W)	Maximum dough capacity (kg)	Maximum flour capacity (kg)	Bowl volume(L)	Bowl diameter(mm)	40 HQ Container loading
STMF60	1210x720x1430	380-440/50,60	3700/2000	550	60	37.5	115	670	28
STMF80	1210x720x1430	380-440/50,60	2600/5200	550	80	50	129	670	28
STMF120	1240x785x1500	380-440/50,60	3700/7500	750	120	75	189	750	23
STMF160	1425x946x1715	380-440/50,60	10000/5500	1100	160	100	260	910	14
STMF200	1425x946x1715	380-440/50,60	12000/7500	1100	200	125	306	910	14

BAKERY DOUGH SHEETER



TMK520B



TMK520L

Model	Product Dim (W/D/H mm)	Voltage/ Frequency (V/Hz)	Power (W)	Working Width(mm)	Conveyer Table Length(mm)	Gap between Rollers(mm)	Conveyer belt size(mm) W/L	40 HQ Container loading
TMK520B	2080x880x620	380/50	400	500	990	0.3-35	500x2000	56
TMK520L	2950x880x1170	380/50	750	500	1190	0.3-35	500x2400	28

HORIZONTAL CUTTER STAND

- With copper motor
- Stainless steel body and knives
- Highly close to manual knife chopping
- With waterproof switch
- With non-slip feet



HCH209



HCH2010

Model	Product Dim (W/D/H mm)	Volume of bucket(L)	Capacity(kg/h)	Voltage /Frequency (V/Hz)	Power (W)	40 HQ Container loading
HCH209	899x707x926	20	5-10	220-240/50-60	1500	56
HCH2010	907x699x1025	20	5-10	220-240/50-60	1500	56

FOOD PROCESSING EQUIPMENT

HAND BLENDER

- Professional equipment particularly suited for ice cream shops, confectionery, restaurants and hotels etc.
- Elegant body design made from plastic, heavy duty hand mixer available in 4 motor sizes to meet the demands of any kitchens.
- 280W, 450W, 650W and 850W ventilated motors, thermal overload protection and variable speed control switch.
- Ergonomic handle for comfortable use.
- Full stainless steel, high performance blade, all food contact parts in stainless steel.



Model	Product Dim(W/D/H mm)	Voltage /Frequency (V/Hz)	Power (W)	Speed (r/min)	40 HQ Container loading
STHMMMA16N	544x75x75	100-120/60 220-240/50	280	20000	6300
STHMMLA16N	544x75x75	100-120/60 220-240/50	280	6000-20000	6300
STMA45N	359x190x91	100-120/60 220-240/50	450	16000	2520
STMLA45N	359x190x91	100-120/60 220-240/50	450	4000-16000	2520
STMA65N	396x220x116	100-120/60 220-240/50	650	18000	2205
STMLA65N	396x220x116	100-120/60 220-240/50	650	8000-18000	2205
STMA85N	396x220x116	100-120/60 220-240/50	850	18000	2205
STMLA85N	396x220x116	100-120/60 220-240/50	850	8000-18000	2205



STMLA45N, STMLA65N, STMLA85N for choice



RBA25



WHMMA



THMMA

Model	Product Dim(W/D/H mm)	40 HQ Container loading
RBA25	118x118x388	2940
WHMMA	270x89x65	25200
THMMA	600x400x50	12600

SPINDLE MIXER

- Ideal for the preparation of smoothies, milkshakes and cocktails.
- Anti-slip feet for a safe stand
- Compact and space-saving
- Long service life is guaranteed due to the stainless steel drive shaft
- Corrosion resistant and scratch resistant
- Precision motor minimises vibrations



Model	Product Dim(W/D/H mm)	Voltage /Frequency (V/Hz)	Power (W)	Net Volume(L)	40 HQ Container loading
SPMET1B	230x230x495	220-240/50,60	300	0.9	1280
SPMET1W	230x230x495	220-240/50,60	300	0.9	1280

- Ideal for the preparation of smoothies, milkshakes and cocktails.
- Anti-slip feet for a safe stand
- Compact and space-saving
- Long service life is guaranteed due to the stainless steel drive shaft
- Corrosion resistant and scratch resistant
- Precision motor minimises vibrations



Model	Product Dim(W/D/H mm)	Voltage /Frequency (V/Hz)	Power (W)	Net Volume(L)	40 HQ Container loading
SPMET1	230x230x495	220-240/50,60	300	0.9	1280
SPMET2	330x160x500	220-240/50,60	600	0.9+0.9	1280



- 2 speed levels
- Safety microswitch
- High performance with low energyconsumption
- With non-slip rubber feet
- Ideal for milkshakes, protein shakes, cocktails, etc.

Model	Product Dim(W/D/H mm)	Voltage/ Frequency (V/Hz)	Power (W)	Net Volume(L)	40 HQ Container loading
CMVA1	170x170x510	230/50	80	1	1958
CMVA2	360x170x510	230/50	80+80	1+1	968

FOOD PROCESSING EQUIPMENT

CHURRO MACHINE



Model	Product Dim (W/D/H mm)	Filling Volume(L)	NW/GW(kg)	40 HQ Container loading
CHMNP5	190x130x590	5	10.2/10.82	612
CHMNP3	180x130x580	3	8.42/9.36	952
UGCHMNP44	440x550x380	/	3.4/3.98	5568
UGCHMNP76	700x550x380	/	3.8/4.52	5568
UGVCHMNP76	700x580x380	/	3.88/4.64	5568

MANUAL DONUT TOOL



DMMNP

Model	Product Dim (W/D/H mm)	NW/GW(kg)	40 HQ Container loading
DMMNP	160x160x390	0.8/1	1568

HOPPER



FMCNP1



FMNP1



FMNP04

Model	Product Dim (W/D/H mm)	NW/GW(kg)	40 HQ Container loading
FMCNP1	190x190x400	0.8/1	3380
FMNP1	130x250x220	0.45/0.5	6300
FMNP04	100x140x150	0.3/0.5	16354

HOPPER



OFTH125

Model	Product Dim (W/D/H mm)	NW/GW(kg)	40 HQ Container loading
OFTH125	Φ135x270	0.42/7.3	8114



CFTH15



CFTH18A



CFTH18AT

Model	Product Dim (W/D/H mm)	NW/GW(kg)	40 HQ Container loading
CFTH15	Φ170x H:255	1/10.3	4968
CFTH18A	Φ194x H:265	0.8/9.06	4968
CFTH18AT	Φ194x H:295	0.91/9.9	4968

FILLING MACHINE



FMTNP

Model	Product Dim (W/D/H mm)	NW/GW(kg)	40 HQ Container loading
FMTNP	80x200x450	0.9/1	5610



FMSA10



FMMSA10

- Various applications - for portioning creams, oils, or e.g. pastes.
- Adjusting the filling quantity by means of a rotary knob
- Funnel and the filling elements made of stainless steel
- Filling accuracy: +/- 1%
- Easy to operate
- Easy to clean

Model	Product Dim(W/D/H mm)	Product category	Capacity (L)	Filling range(ml)	40 HQ Container loading
FMSA10	285x285x720	Pneumatic filling machine	10	0-50	756
FMMSA10	285x285x720	Manual type filling machine	10	0-50	756

ELECTRIC OIL PRESS

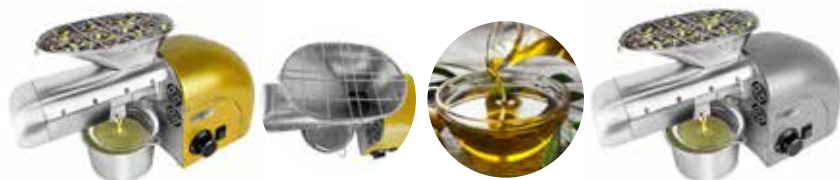

EOPMCH-Gold

EOPMCH-Grey

- Comes with a safety protection net
- 360-degree anti-scalding design
- Adjustable temperature between 0 °C to 300 °C
- Made of stainless steel, with a beautiful appearance and unique design

Model	Product Dim(W/D/H mm)	Voltage /Frequency (V/Hz)	Power (W)	Capacity (kg/h)	40 HQ Container loading
EOPMCH-Gold	190x500x290	220-240/50-60	1800	5	1080
EOPMCH-Grey	190x500x290	220-240/50-60	1800	5	1080

JUICE EXTRACTOR



FSET6



FSET28

Model	Product Dim(W/D/H mm)	Voltage /Frequency (V/Hz)	Power (W)	40 HQ Container loading
FSET6	300x190x340	220-240/50,60	180	1280
FSET28	400x250x460	220-240/50,60	600	1280



FSK200

- Casting aluminum body
- Waterproof motor block
- 3 removable suqeezer cones



FSK300

- Simple design for easy operation
- Stainless steel with mirror polish as professional appearance



FSK400

- Suitable for fruit and vegetable
- Microswitch safety system
- Overload switch
- Simple design for easy operation
- Separate juice from pericarp

Model	Product Dim(W/D/H mm)	Voltage /Frequency (V/Hz)	Power (W)	40 HQ Container loading
FSK200	218x308x354	220-240/50,60	180	1300
FSK300	287x212x470	220-240/50,60	230	1180
FSK400	390x270x500	220-240/50,60	600	800

FOOD MIXER

- BPA-free
- Automatic shut-off function in case of overheating
- Quiet operation
- Powerful motor
- Adjustable revs
- Very simple manual operation
- Long service life
- Easy to clean
- Containers are not dishwasher safe
- Plastic casing



FMK1500

Model	Product Dim(W/D/H mm)	Voltage /Frequency (V/Hz)	Power (W)	Net Capacity(L)	Best (r/min)	40 HQ Container loading
FMK1500	185x240x520	220-240/50,60	1500	2	25000-28000	1620

- Large LCD screen.Sealing strip Sound Cover
- Professional sound insulation cover design
- Automatic memory of the last usage programs
- 185kinds of pro modes
- Automatic shut Off for Overload Protection
- No Plunger Needed.Optional Jar magnet device
- Special heat treatment Stainless steel Blades from Japan
- Stainless steel Double-bearings
- Double waterproof bearing chamber structure



BMK2-1500



BMK2-2200

- Variable Speed control,Pulse and power switch
- Automatic shut Off for Overload
- Protection Optional Plunger Needed

Model	Product Dim(W/D/H mm)	Voltage /Frequency (V/Hz)	Power (W)	Net Capacity(L)	Rabbit Size(mm)	Best (r/min)	40 HQ Container loading
BMK2-1500	220x260x500	220-240/50,60	1500	2	150x150x150	28000	996
BMK2-2200	220x240x480	220-240/50,60	1500	2	140x140x140	28000-30000	1176

ORANGE SQUEEZER

- Stainless steel water tray
- Powerful and stable motor
- Strengthen protection switch
- Automatic feeding fruit
- Automatic tap control
- Easy operation and easy cleaning



OPB20E



OPET20

- Automatic fruit supply
- Particularly suitable for buffets and restaurants
- Strong and reliable
- Stainless steel housing
- Powerful motor
- Easy to use
- Easy to clean

Model	Product Dim(W/D/H mm)	Voltage /Frequency (V/Hz)	Power (W)	Size of orange required(mm)	Output per minute	40 HQ Container loading
OPB20E	400x450x900	220-240/50,60	200	Φ60-80	20	152
OPET20	640x450x780	230/50	120	Φ40-80	20	160

FOOD PROCESSING EQUIPMENT

VACUUM MACHINE



- Multi-language
- User-friendly
- Durable electric units
- 3mm thickness
- Formed by mould
- Hings absorb shocks
- Long life
- Not easily deformation
- Seamless
- Safty for operator

Model	Product Dim(W/D/H mm)	Voltage /Frequency (V/Hz)	Power (W)	Pump Capacity(m ³ /h)	Sealing Length(mm)	Sealing Width(mm)	Vacuum Chamber Depth(mm)	40 HQ Container loading
VMKH-300	385x510x370	230/50	370	10	290	5	55	560
VMKH-400Z	500x540x480	230/50	900	20	390	10	65	250
VMKH-4002	500x540x905	230/50	900	20	390	10	65	160
VMKH-500	590x645x920	230/50	900	20	490	10	70	125



VGFW2018

- Sealers Vacuum Food Saver.Press it and automatically vacuuming
- Press the button to seal bag without vacuuming
- You can choose the dry indication for solid food items and the moist indication for poached food.
- Keep food fresh up to 5 times longer than other storage methods

Model	Product Dim(W/D/H mm)	Pump Vacuum Liter(L/m)	Voltage /Frequency (V/Hz)	Power (W)	Sealing Length(mm)	Sealing Width(mm)	Lock	40 HQ Container loading
VGFW2018	390x150x67	12	110-240/50,60	110	320	3	Handy Press	5923

MOBILE GLASS WASHER



MGSX600

- Easy to install and use
- Water saving, more than 70%
- Zero power consumption, energy-saving and environmental
- Perfect washing performance with cold water
- Will not broken the glass
- Will clean the lipstick and other besmirch easily and clearly
- Suitable for all types of glass
- Esthetical designed
- Compact and light, you can put it anywhere

Model	Product Dim (W/D/H mm)	Production Capacity(pcs/hour)	40 HQ Container loading
MGSX600	380x200x360	600	1920

DISH WASHER

- Body made by stainless steel
- 360 degree rotating spray
- Continuous high temperature disinfection at 80-85 degrees Celsius
- Compact and space-saving



DH300



DH3050



DH430

Model	Product Dim(W/D/H mm)	Capacity(basket/h)	Voltage /Frequency (V/Hz)	Power (W)	Volume of bucket (L)	40 HQ Container loading
DH300	476x550x720	30	380-415/50,60	5550	20	219
DH3050	600x610x820	30	380-415/50,60	7000	20	102
DH430	706x873x1473	60	380-415/50,60	14500	33	26

HONEY EXTRACTOR

- Powerful electric motor with different speed options
- Made of stainless steel
- Suitable for frame size: 23,50 mm x 44 mm x 48,80 mm
- With 3 height adjustable feet
- Easy mounting
- Easy to use



HSEWU3

Model	Product Dim (W/D/H mm)	Net capacity (L)	Voltage /Frequency (V/Hz)	Rated Speed(r/min)	Power (W)	40 HQ Container loading
HSEWU3	380x380x605	90	220-240/50	180	140	168

SESAME PEANUT BUTTER MACHINE

- Sesame and peanut butter machine is a machine that can grind tahini paste, peanut butter, soybean milk, rice milk, starch pulp and chemical raw material pulp.
- It has the advantages of small size, easy handling, easy operation, low noise, high efficiency, fine grinding, low temperature, no heat grinding and so on, and is the ideal machine to replace the traditional stone grinding.



SMHB

Model	Product Dim(W/D/H mm)	Voltage /Frequency (V/Hz)	Power (W)	Capacity(kg/h)	40 HQ Container loading
SMHB	320x320x700	220-240/50	1100	15	850

FOOD PROCESSING EQUIPMENT

POULTRY PLUCKER



GRMWX119

GRMWX136
GRMWX184

GRMWX211

- Poultry plucking machine for quails, pigeons, chicks, etc.
- Without integrated water flushing.
- With spring ejection chute to keep the springs in one place
- Hand protection for safe operation
- Ideal for use in the catering industry, agriculture or even in slaughterhouses
- This plucker is perfect for plucking quail, pigeons, chicks and smaller birds
- Housing made of high quality stainless steel
- Easy to clean

Model	Product Dim(W/D/H mm)	Voltage /Frequency (V/Hz)	Power (W)	Capacity(pcs/min)	Engine Speed (r/min)	40 HQ Container loading
GRMWX119	347x347x670	220-240/50,60	1500	1-2	1350	540
GRMWX136	570x570x950	220-240/50,60	1500	3-4	1400	120
GRMWX184	660x660x950	220-240/50,60	1500	5-6	1400	120
GRMWX211	860x860x1027	220-240/50,60	2200	8-10	1400	48

POULTRY PLUCKER AND SCALDER

- Plucking machine with integrated scalding tank for poultry
- Ideal for use in the catering industry, agriculture or even in slaughterhouses
- With digital thermostat
- Temperature: 30 °C to 110 °C
- With automatic temperature limiter
- With water inlet & water valve on the side wall
- Easy to move due to the 4 attached wheels
- With spring ejection chute to keep the springs in one place
- Housing made of high quality stainless steel
- Aluminum engine

GRMWX50
GRMWX55
GRMWX60

Model	Product Dim(W/D/H mm)	Voltage /Frequency (V/Hz)	Power (W)	Capacity(pcs/min)	40 HQ Container loading
GRMWX50	1020x554x955	220-240/50,60	1500	3-4	60
GRMWX55	1122x602x955	220-240/50,60	1500	4-5	60
GRMWX60	1221x652x955	220-240/50,60	1500	5-6	54

SCALDING KETTLE POULTRY

- Scalding kettle for poultry
- Ideal for use in the catering industry, agriculture or even in slaughterhouses
- Brewing time: 70-180 seconds
- With digital thermostat
- With automatic temperature limiter
- With water inlet and water valve on the side wall
- Housing made of high quality stainless steel



BKWX70

Model	Product Dim(W/D/H mm)	Voltage /Frequency (V/Hz)	Power (W)	Capacity(L)	Operation temperature(°C)	overheat protection temperature(°C)	40 HQ Container loading
BKWX70	450x350x670	220-240/50,60	1800	70	30~110	130	506

HAND DRYER

- There is blue half circle LED light to guide user to air flow.
- Customized ON/OFF switch for heat element.
- 360° revolving air nozzle.
- 60 Seconds continuous running automatic cut-off protection.
- Built in electronic infrared sensor

- Space saving and the jet hand dryer protrudes less than 195mm from the wall.
- Brushless powerful motor and HEPA filter to create clean air without bacteria.
- Dry hands in 7 seconds by super-powered Jet air.
- ECO friendly and cost saving.
- High traffic and heavy duty hand dryer.



Model	Product Dim(W/D/H mm)	Voltage /Frequency (V/Hz)	Power (W)	Air temperature (°C)	Air speed(m/s)	Drying time(s)	Continuous working time(s)	40 HQ Container loading
EHTDKE15	262x208x231	220-240/50,60	2300	45	26	15-20	60	2464
EHTKE15	262x208x231	220-240/50,60	2300	45	26	15-20	60	2464
HTEKE7	297x195x671	220-240/50,60	1650	40	130	7-9	25	832
HTWKE7	297x195x671	220-240/50,60	1650	40	130	7-9	25	832

SHOE POLISHER

- With two detachable soft brushes
- With replaceable shoe wax bottle
- With one hard brush



SPMFE

Model	Product Dim(W/D/H mm)	Voltage /Frequency (V/Hz)	Power(W)	With Handle or Not	40 HQ Container Loading
SPMFE	400X240X245	230/50	120	Yes	1706

CAN OPENER

- Safe design, does not hurt hands
- Easy to operate, efficient and fast
- Suitable for cans of different heights



DOH750
DOH500

Model	Product Dim(W/D/H mm)	Net weight (kg)	Gross weight (kg)	40 HQ Container loading
DOH750	750x200x120	1.8	13 (8pcs/carton)	5712
DOH500	500x200x120	1.55	11 (8pcs/carton)	8190

FOOD PROCESSING EQUIPMENT

JUICE EXTRACTOR MANUALLY

- Energy saving
- Ergonomic handle
- Stainless steel pressing cone
- Long rubber handle for better leverage
- High stability due to U-shaped design of the foot
- Easy to use
- Easy to clean



FSPSH-SI



FSPSH-W



FSPSH-S



FSPSH-B

Model	Product Dim(W/D/H mm)	Color	40HQ Container loading
FSPSH-SI	185x250x490	Silver	2052
FSPSH-W	185x250x490	White	2052
FSPSH-S	185x250x490	Black	2052
FSPSH-B	185x250x490	Bronze	2052

KNIFE SHARPENER

- Low motor sound
- There are rough grinding, fine grinding, and specialized cutting edges for grinding scissors
- Simple and durable appearance



MSSRSS



MSSSES

- Simple and durable appearance, with stainless steel elements showing a more high-end atmosphere
- There are rough grinding, fine grinding, and specialized cutting edges for grinding scissors

Model	Product Dim(W/D/H mm)	Voltage /Frequency (V/Hz)	Power(W)	Capacity(pcs/day)	40 HQ Container Loading
MSSRSS	220x88x73	100-240/50,60	50	1500	9856
MSSSES	218x66x77	100-240/50,60	12	1500	12800

MANUAL STAINLESS STEEL SAUSAGE CLIPPER

- Entirely made of high quality stainless steel
- Desktop unit
- Diameter: 45 - 120 mm
- Simple, manual operation via lever
- Strong closure of the sausage filling
- Leakage of the filling impossible
- Easy to clean



MWCH1

Model	Product Dim(W/D/H mm)	Package Dim(W/D/H mm)	NW/GW(kg)	40 HQ Container loading
MWCH1	400x180x610	425x220x660	10.5/11.5	1360

ICE CRUSHER

- Material: Plastic Shell And Aluminium Hopper
- Simple design for easy operation



TECK03



ECTA80

- Base made in aluminum alloy
- Stainless steel container
- Strong cutlery steel blade
- Safety microswitch included
- High capacity for professional use
- Ventilated motor with gear transmission for prolonged use
- The machine is designed and produced according to international standards for safety and hygiene.

Model	Product Dim(W/D/H mm)	Speed(r/min)	Voltage /Frequency (V/Hz)	Power (W)	40 HQ Container loading
TECK03	190x420x290	1450	230/50	300	1600
ECTA80	328x197x533	1000	220-240/50	200	960

FOOD TRAILER

- Easy to move, you can move anywhere at any time
- The trailer is fully equipped, and the corresponding equipment can be controlled according to the size of the vehicle
- The appearance of the atmosphere is beautiful, good-looking and practical to attract more customer
- With food trailer as the carrier, save rental rent and work freely
- Low operating costs, but large equity
- Have lower staffing costs.
- Require low initial investment.
- Involves relatively low operation cost.
- Can experiment with location.



MFY-FF2-E



MFY-FF2-G



MFY-FF2-B

Model	Product Dim(W/D/H mm)	Net weight(kg)	Driving type	40 HQ Container loading
MFY-FF2-E	4000x2100x2380	1500	Trailer	2
MFY-FF2-G	2200x1600x2350	450	Trailer	7
MFY-FF2-B	3800x2000x2350	1200	Trailer	3

NEUTRAL PRODUCT





- Work table
- Top shelf
- Heating light
- Drawer block - base module
- Rubbish bin - substructure module
- Stainless steel chopping block
- Meat table
- Sink unit with floor base
- Dishwasher sink
- Hand wash sink
- Stainless steel sink cabinet
- Dishwasher cabinet
- Stainless steel work cabinet
- Beverage dispenser base cabinet
- Substructure
- Rubbish bin with roll container
- Flour trolley
- Litter bin with lift lid
- Drawer cabinet
- Corner cabinet
- Corner work table
- Tableware cabinet
- Wall cabinet
- Self assembly
- Stainless steel cash desk
- Wall-hanging cabinet
- Exhaust hood no blower with filter
- Flame protection filter
- Food shelf
- Wall shelves
- Stainless steel shelf
- Trolley
- Stainless steel foldable work table
- Stainless steel cutlery tray
- Wall shelf spice shelf
- Cup dispenser
- S/s pet grooming bathtub
- Coffee grounds drawer
- Insect killer
- Stainless steel gn container
- Milk jug with lid



STAINLESS STEEL FURNITURE

STAINLESS STEEL WORK TABLE- WITH BASE WITHOUT UPSTAND

- High quality stainless steel
- Rounded edges
- Ideal working height
- Very high load capacity
- In addition, individual drawers, as well as drawer tables and waste bins can be installed
- Easy to clean
- Height adjustable feet



ATK147

600 series

Model	Product Dim(W/D/H mm)	40 HQ Container loading
ATK66	600x600x870	683
ATK76	700x600x870	683
ATK86	800x600x870	717
ATK106	1000x600x870	587
ATK126	1200x600x870	490
ATK146	1400x600x870	423
ATK156	1500x600x870	397
ATK166	1600x600x870	372
ATK186	1800x600x870	332
ATK206	2000x600x870	300

700 series

Model	Product Dim(W/D/H mm)	40 HQ Container loading
ATK67	600x700x870	597
ATK77	700x700x870	597
ATK87	800x700x870	617
ATK107	1000x700x870	511
ATK127	1200x700x870	428
ATK147	1400x700x870	370
ATK157	1500x700x870	345
ATK167	1600x700x870	324
ATK187	1800x700x870	290
ATK207	2000x700x870	261

800 series

Model	Product Dim(W/D/H mm)	40 HQ Container loading
ATK108	1000x800x870	409
ATK128	1200x800x870	343
ATK148	1400x800x870	295
ATK158	1500x800x870	276
ATK168	1600x800x870	259
ATK188	1800x800x870	230
ATK208	2000x800x870	208

STAINLESS STEEL WORK TABLE -WITH BASE WITH UPSTAND

- High quality stainless steel
- Rounded edges
- Ideal working height
- Very high load capacity
- In addition, individual drawers, as well as drawer tables and waste bins can be installed
- Easy to clean
- Height adjustable feet
- Splash back is to protect and prevent wall from any spillages, grease stains or water marks



ATK147A

600 series

Model	Product Dim(W/D/H mm)	40 HQ Container loading
ATK66A	600x600x870+100	526
ATK76A	700x600x870+100	526
ATK86A	800x600x870+100	550
ATK106A	1000x600x870+100	452
ATK126A	1200x600x870+100	380
ATK146A	1400x600x870+100	327
ATK156A	1500x600x870+100	306
ATK166A	1600x600x870+100	287
ATK186A	1800x600x870+100	256
ATK206A	2000x600x870+100	231

700 series

Model	Product Dim(W/D/H mm)	40 HQ Container loading
ATK67A	600x700x870+100	461
ATK77A	700x700x870+100	461
ATK87A	800x700x870+100	477
ATK107A	1000x700x870+100	394
ATK127A	1200x700x870+100	330
ATK147A	1400x700x870+100	285
ATK157A	1500x700x870+100	267
ATK167A	1600x700x870+100	251
ATK187A	1800x700x870+100	224
ATK207A	2000x700x870+100	202

800 series

Model	Product Dim(W/D/H mm)	40 HQ Container loading
ATK108A	1000x800x870+100	390
ATK128A	1200x800x870+100	327
ATK148A	1400x800x870+100	281
ATK158A	1500x800x870+100	262
ATK168A	1600x800x870+100	246
ATK188A	1800x800x870+100	219
ATK208A	2000x800x870+100	198

STAINLESS STEEL WORK TABLE - WITH SUPPORT WITHOUT SHELF AND UPSTAND



ATK167V

- High quality stainless steel
- Easy to assemble
- Without the splash back can be spliced together

600 series

Model	Product Dim(W/D/H mm)	40 HQ Container loading
ATK106V	1000x600x870	587
ATK126V	1200x600x870	490
ATK146V	1400x600x870	423
ATK156V	1500x600x870	397
ATK166V	1600x600x870	372
ATK186V	1800x600x870	332
ATK206V	2000x600x870	300

700 series

Model	Product Dim(W/D/H mm)	40 HQ Container loading
ATK107V	1000x700x870	511
ATK127V	1200x700x870	428
ATK147V	1400x700x870	370
ATK157V	1500x700x870	345
ATK167V	1600x700x870	324
ATK187V	1800x700x870	290
ATK207V	2000x700x870	261

STAINLESS STEEL WORK TABLE - WITHOUT SHELF WITH SUPPORT AND UPSTAND



ATK167AV

- High quality stainless steel
- Easy to assemble
- Height adjustable 870-970mm
- With the splash back to prevent water from splashing onto the wall

600 series

Model	Product Dim(W/D/H mm)	40 HQ Container loading
ATK106AV	1000x600x870+100	587
ATK126AV	1200x600x870+100	490
ATK146AV	1400x600x870+100	423
ATK156AV	1500x600x870+100	397
ATK166AV	1600x600x870+100	372
ATK186AV	1800x600x870+100	332
ATK206AV	2000x600x870+100	300

700 series

Model	Product Dim(W/D/H mm)	40 HQ Container loading
ATK107AV	1000x700x870 +100	394
ATK127AV	1200x700x870 +100	330
ATK147AV	1400x700x870 +100	285
ATK157AV	1500x700x870 +100	267
ATK167AV	1600x700x870 +100	251
ATK187AV	1800x700x870 +100	224
ATK207AV	2000x700x870 +100	202

STAINLESS STEEL FURNITURE

STAINLESS STEEL WORK TABLE - WITH BASE & UPSTAND AT THE BACK + RIGHT

- High quality stainless steel
- Easy to assemble
- Can be added with layers to make three layers
- The undershelf can be replaced by a support, front opening
- Height adjustable 870-970mm
- Two choices with and without splash back: with the splash back to prevent water from splashing onto the wall, without the splash back can be spliced together



ATK66AA

Model	Product Dim(W/D/H mm)	40 HQ Container loading
ATK66AA	600x600x870+100	526
ATK77AA	700x700x870+100	461

TOP SHELF

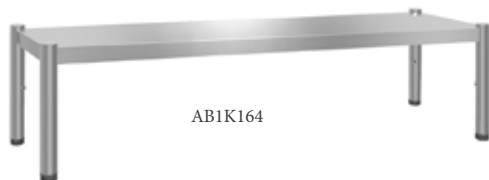

AB1K164

- High quality stainless steel
- Rounded edges
- Very high load capacity
- 2 adjustable tier(s)
- Easy to clean
- Soundproof footplates
- Can be installed with heating light



AB2K147

400 series

Model	Product Dim(W/D/H mm)	40 HQ Container loading
AB1K84	800x370x400	3227
AB1K104	1000x370x400	2536
AB1K124	1200x370x400	2152
AB1K144	1400x370x400	1821
AB1K164	1600x370x400	1614
AB1K184	1800x370x400	1420
AB1K204	2000x370x400	1291

700 series

Model	Product Dim(W/D/H mm)	40 HQ Container loading
AB2K87	800x370x700	2029
AB2K107	1000x370x700	1614
AB2K127	1200x370x700	1365
AB2K147	1400x370x700	1164
AB2K167	1600x370x700	1029
AB2K187	1800x370x700	910
AB2K207	2000x370x700	816

HEATING LIGHT

Heating light 2 Lights



KBK7-2
KBK9-2

Heating light 3 Lights



KBK11-3
KBK13-3

Heating light 4 Lights



KBK15-4
KBK17-4

Heating light 5 Lights



KBK19-5

- High quality heating elements
- Infrared heating
- Easy to be installed with over shelf

Model	Product Dim(W/D/H mm)
KBK7-2	726x120x80
KBK9-2	926x120x80
KBK11-3	1126x120x80
KBK13-3	1326x120x80
KBK15-4	1526x120x80
KBK17-4	1726x120x80
KBK19-5	1926x120x80

DRAWER BLOCK - BASE MODULE



SE1K46
SE1K47
SE1K48

- High quality stainless steel
- Easy to assemble with working table
- Silent pulley for drawers



ST2K46
ST2K47
ST2K48



ST3K46
ST3K47
ST3K48



- High quality stainless steel
- Easy to assemble with working table
- Silent pulley for drawers
- Different drawers that can be stored separately

Model	Product Dim(W/D/H mm)	40 HQ Container loading
SE1K46	400x560x150	1520
SE1K47	400x660x150	1296
SE1K48	400x760x150	1125
ST2K46	400x560x585	420
ST2K47	400x660x585	360
ST2K48	400x760x585	280
ST3K46	400x560x585	420
ST3K47	400x660x585	360
ST3K48	400x760x585	280

STAINLESS STEEL FURNITURE

RUBBISH BIN - SUBSTRUCTURE MODULE



MEK46
MEK47
MEK48

- High quality stainless steel
- Easy to assemble with working table

Model	Product Dim(W/D/H mm)	40 HQ Container loading
MEK46	400x560x585	420
MEK47	400x660x585	360
MEK48	400x760x585	280

STAINLESS STEEL CHOPPING BLOCK



FTK55

- Body made of high quality stainless steel
- 80mm Polyethylene worktop
- Perfect for processing: meat, vegetables, fish
- Easy to clean

Model	Product Dim(W/D/H mm)	40 HQ Container loading
FTK55	500x500x870	271

MEAT TABLE



FTK166

- Body made of high quality stainless steel
- Polyethylene work surface
- Perfect for processing: meat, vegetables, fish
- Easy to clean



Model	Product Dim(W/D/H mm)	40 HQ Container loading
FTK126	1200x600x870	490
FTK146	1400x600x870	423
FTK166	1600x600x870	372
FTK186	1800x600x870	332
FTK206	2000x600x870	300

Model	Product Dim(W/D/H mm)	40 HQ Container loading
FTK127	1200x700x870	430
FTK147	1400x700x870	370
FTK167	1600x700x870	326
FTK187	1800x700x870	290
FTK207	2000x700x870	261

STAINLESS STEEL SINK - WITH BASE - 1 BASIN ON THE LEFT



STK126BL1

- High quality stainless steel
- Easy to Maintain & Clean, this sink adopts streamlined rounded corners and edge design, convenient for daily washing

600 series

Model	Product Dim(W/D/H mm)	40 HQ Container loading
STK106BL1	1000x600x870+100	226
STK126BL1	1200x600x870+100	219
STK146BL1	1400x600x870+100	189

700 series

Model	Product Dim(W/D/H mm)	40 HQ Container loading
STK107BL1	1000x700x870+100	201
STK127BL1	1200x700x870+100	169
STK147BL1	1400x700x870+100	145

STAINLESS STEEL SINK - WITH BASE - 1 BASIN ON THE RIGHT



STK1146BR1

- High quality stainless steel
- Easy to assemble
- Top is stretch, easy to clean
- Bowl is stretch: dedicated custom molds for bowl and drainage more easily
- Grooved board
- Height adjustable 870-970mm

600 series

Model	Product Dim(W/D/H mm)	40 HQ Container loading
STK106BR1	1000x600x870+100	226
STK126BR1	1200x600x870+100	219
STK146BR1	1400x600x870+100	189

700 series

Model	Product Dim(W/D/H mm)	40 HQ Container loading
STK107BR1	1000x700x870+100	201
STK127BR1	1200x700x870+100	169
STK147BR1	1400x700x870+100	145

STAINLESS STEEL SINK - WITH BASE - 2 BASINS ON THE LEFT



STK146BL2

- High quality stainless steel
- Easy to assemble
- Top is stretch, easy to clean
- Bowl is stretch: dedicated custom molds for bowl and drainage more easily
- Grooved board
- Height adjustable 870-970mm

600 series

Model	Product Dim(W/D/H mm)	40 HQ Container loading
STK146BL2	1400x600x870+100	189
STK166BL2	1600x600x870+100	166
STK186BL2	1800x600x870+100	148
STK206BL2	2000x600x870+100	134

700 series

Model	Product Dim(W/D/H mm)	40 HQ Container loading
STK147BL2	1400x700x870+100	164
STK167BL2	1600x700x870+100	128
STK187BL2	1800x700x870+100	114
STK207BL2	2000x700x870+100	103

STAINLESS STEEL FURNITURE

STAINLESS STEEL SINK - WITH BASE - 2 BASINS ON THE RIGHT



STK146BR2

- High quality stainless steel
- Easy to assemble
- Top is stretch, easy to clean
- Bowl is stretch: dedicated custom molds for bowl and drainage more easily
- Grooved board
- Height adjustable 870-970mm

600 series

Model	Product Dim(W/D/H mm)	40 HQ Container loading
STK146BR2	1400x600x870+100	189
STK166BR2	1600x600x870+100	166
STK186BR2	1800x600x870+100	148
STK206BR2	2000x600x870+100	134

700 series

Model	Product Dim(W/D/H mm)	40 HQ Container loading
STK147BR2	1400x700x870+100	164
STK167BR2	1600x700x870+100	128
STK187BR2	1800x700x870+100	114
STK207BR2	2000x700x870+100	103

STAINLESS STEEL SINK - WITH BASE - 2 BASINS IN THE MIDDLE

- High quality stainless steel
- Easy to assemble
- Top is stretch, easy to clean
- Bowl is stretch: dedicated custom molds for bowl and drainage more easily
- Grooved board
- Height adjustable 870-970mm



STK206BM2

Model	Product Dim(W/D/H mm)	40 HQ Container loading
STK206BM2	2000x600x870+100	134
STK207BM2	2000x700x870+100	103

STAINLESS STEEL SINK - WITH BASE - 1 BASIN



STK66BM1

- High quality stainless steel
- Easy to assemble
- Top is stretch, easy to clean
- Bowl is stretch: dedicated custom molds for bowl and drainage more easily
- Height adjustable 870-970mm

600 series

Model	Product Dim(W/D/H mm)	40 HQ Container loading
STK66BM1	600x600x870+100	418
STK86BM1	800x600x870+100	321

700 series

Model	Product Dim(W/D/H mm)	40 HQ Container loading
STK67BM1	600x700x870+100	362
STK87BM1	800x700x870+100	247

DISHWASHER SINK - 1 BASIN ON THE LEFT/RIGHT



STK126SBL1



STK127SBR1

- High quality stainless steel
- Easy to assemble
- Top is stretch, easy to clean
- Bowl is stretch: dedicated custom molds for bowl and drainage more easily
- Grooved board
- Height adjustable 870-970mm
- One side is open, and other equipment can be placed underneath

600 series

Model	Product Dim(W/D/H mm)	40 HQ Container loading
STK126SBL1	1200x600x870+100	219
STK146SBL1	1400x600x870+100	189
STK126SBR1	1200x600x870+100	219
STK146SBR1	1400x600x870+100	189

700 series

Model	Product Dim(W/D/H mm)	40 HQ Container loading
STK127SBL1	1200x700x870+100	190
STK147SBL1	1400x700x870+100	145
STK127SBR1	1200x700x870+100	190
STK147SBR1	1400x700x870+100	145

DISHWASHER SINK - 2 BASINS ON THE LEFT/RIGHT



STK186SBL2



STK186SBR2

600 series

Model	Product Dim(W/D/H mm)	40 HQ Container loading
STK166SBL2	1600x600x870+100	166
STK186SBL2	1800x600x870+100	148
STK206SBL2	2000x600x870+100	134
STK166SBR2	1600x600x870+100	166
STK186SBR2	1800x600x870+100	148
STK206SBR2	2000x600x870+100	134

700 series

Model	Product Dim(W/D/H mm)	40 HQ Container loading
STK167SBL2	1600x700x870+100	128
STK187SBL2	1800x700x870+100	114
STK207SBL2	2000x700x870+100	103
STK167SBR2	1600x700x870+100	128
STK187SBR2	1800x700x870+100	114
STK207SBR2	2000x700x870+100	103

STAINLESS STEEL FURNITURE

HAND WASH SINK



HWR56K
HWR57K

- High quality stainless steel
- Easy to assemble with over shelf
- Stretch bowl

Model	Product Dim(W/D/H mm)	40 HQ Container loading
HWR56K	500x600x870+30	355
HWR57K	500x700x870+30	306

STAINLESS STEEL SINK - 1 BOWL

- High quality stainless steel
- Wing door(s)
- Rounded edges
- Height adjustable feet



SSK66BM1



SSK86BM1

600 series

Model	Product Dim(W/D/H mm)	40 HQ Container loading
SSK66BM1	600x600x870+100	156
SSK86BM1	800x600x870+100	118

700 series

Model	Product Dim(W/D/H mm)	40 HQ Container loading
SSK67BM1	600x700x870+100	134
SSK87BM1	800x700x870+100	102

STAINLESS STEEL SINK CABINET - 1 BASIN ON THE LEFT

- High quality stainless steel
- 2 sliding doors
- Easy to clean



SSK126BL1

600 series

Model	Product Dim(W/D/H mm)	40 HQ Container loading
SSK106BL1	1000x600x870+100	104
SSK126BL1	1200x600x870+100	87
SSK146BL1	1400x600x870+100	75

700 series

Model	Product Dim(W/D/H mm)	40 HQ Container loading
SSK107BL1	1000x700x870+100	90
SSK127BL1	1200x700x870+100	75
SSK147BL1	1400x700x870+100	65

STAINLESS STEEL SINK CABINET - 1 BASIN ON THE RIGHT

- High quality stainless steel
- Top is stretch, easy to clean
- Bowl is stretch: dedicated custom molds for bowl and drainage more easily
- Grooved board
- The door is double-layered and more stable
- The door sounds small and quiet.
- The door is easy to disassemble
- Height adjustable 870-970mm



SSK126BR1

600 series

Model	Product Dim(W/D/H mm)	40 HQ Container loading
SSK106BR1	1000x600x870+100	104
SSK126BR1	1200x600x870+100	87
SSK146BR1	1400x600x870+100	75

700 series

Model	Product Dim(W/D/H mm)	40 HQ Container loading
SSK107BR1	1000x700x870+100	90
SSK127BR1	1200x700x870+100	75
SSK147BR1	1400x700x870+100	65

STAINLESS STEEL SINK CABINET - 2 BOWLS LEFT



SSK186BL2

600 series

Model	Product Dim(W/D/H mm)	40 HQ Container loading
SSK146BL2	1400x600x870+100	75
SSK166BL2	1600x600x870+100	66
SSK186BL2	1800x600x870+100	59
SSK206BL2	2000x600x870+100	53

700 series

Model	Product Dim(W/D/H mm)	40 HQ Container loading
SSK147BL2	1400x700x870+100	65
SSK167BL2	1600x700x870+100	57
SSK187BL2	1800x700x870+100	51
SSK207BL2	2000x700x870+100	46

STAINLESS STEEL SINK CABINET - 2 BASINS ON THE RIGHT



SSK206BR2

600 series

Model	Product Dim(W/D/H mm)	40 HQ Container loading
SSK146BR2	1400x600x870+100	75
SSK166BR2	1600x600x870+100	66
SSK186BR2	1800x600x870+100	59
SSK206BR2	2000x600x870+100	53

700 series

Model	Product Dim(W/D/H mm)	40 HQ Container loading
SSK147BR2	1400x700x870+100	65
SSK167BR2	1600x700x870+100	57
SSK187BR2	1800x700x870+100	51
SSK207BR2	2000x700x870+100	46

STAINLESS STEEL FURNITURE

STAINLESS STEEL SINK CABINET



SSAAK126BL1S

Bowl left side

Model	Product Dim(W/D/H mm)	40 HQ Container loading
SSAAK126BL1S	1200x600x870+100	84
SSAAK127BL1S	1200x700x870+100	73



SSAAK126BR1S

Bowl right side

Model	Product Dim(W/D/H mm)	40 HQ Container loading
SSAAK126BR1S	1200x600x870+100	84
SSAAK127BR1S	1200x700x870+100	73

STAINLESS STEEL SINK - 2 BASINS IN THE MIDDLE

- High quality stainless steel
- 2 sliding doors
- Back panel open

SSK206BM2
SSK207BM2

Model	Product Dim(W/D/H mm)	40 HQ Container loading
SSK206BM2	2000x600x870+100	53
SSK207BM2	2000x700x870+100	46

DISHWASHER CABINET - 1 BASIN ON THE LEFT

- High-strength stainless steel
- The sink could be fitted with a connection to the dishwasher
- Hinged door(s)



SSK146SBL1

600 series

Model	Product Dim(W/D/H mm)	40 HQ Container loading
SSK126SBL1	1200x600x870+100	87
SSK146SBL1	1400x600x870+100	75

700 series

Model	Product Dim(W/D/H mm)	40 HQ Container loading
SSK127SBL1	1200x700x870+100	75
SSK147SBL1	1400x700x870+100	65

DISHWASHER CABINET - 1 BASIN ON THE RIGHT



SSK126SBR1



SSK146SBR1

600 series

Model	Product Dim(W/D/H mm)	40 HQ Container loading
SSK126SBR1	1200x600x870+100	87
SSK146SBR1	1400x600x870+100	75

700 series

Model	Product Dim(W/D/H mm)	40 HQ Container loading
SSK127SBR1	1200x700x870+100	75
SSK147SBR1	1400x700x870+100	65

DISHWASHER CABINET - 2 BASINS LEFT



SSK166SBL2

- High-strength stainless steel
- The sink cabinet could be fitted with a connection to the dishwasher
- 2 sliding doors

600 series

Model	Product Dim(W/D/H mm)	40 HQ Container loading
SSK166SBL2	1600x600x870+100	66
SSK186SBL2	1800x600x870+100	59
SSK206SBL2	2000x600x870+100	53

700 series

Model	Product Dim(W/D/H mm)	40 HQ Container loading
SSK167SBL2	1600x700x870+100	57
SSK187SBL2	1800x700x870+100	51
SSK207SBL2	2000x700x870+100	46

DISHWASHER CABINET - 2 BASINS ON THE RIGHT



SSK186SBR2

600 series

Model	Product Dim(W/D/H mm)	40 HQ Container loading
SSK166SBR2	1600x600x870+100	66
SSK186SBR2	1800x600x870+100	59
SSK206SBR2	2000x600x870+100	53

700 series

Model	Product Dim(W/D/H mm)	40 HQ Container loading
SSK167SBR2	1600x700x870+100	57
SSK187SBR2	1800x700x870+100	51
SSK207SBR2	2000x700x870+100	46

STAINLESS STEEL FURNITURE

STAINLESS STEEL WORK CABINET - WITHOUT UPSTAND

- Worktop made of double-walled stainless steel
- Work surface without upstand
- Single hinged door or 2 sliding doors



ASK66



ASK126



ASK186

600 series

Model	Product Dim(W/D/H mm)	40 HQ Container loading
ASK66	600x600x870	192
ASK86	800x600x870	131
ASK106	1000x600x870	119
ASK126	1200x600x870	99
ASK146	1400x600x870	86
ASK166	1600x600x870	75
ASK186	1800x600x870	67
ASK206	2000x600x870	60

700 series

Model	Product Dim(W/D/H mm)	40 HQ Container loading
ASK67	600x700x870	167
ASK87	800x700x870	113
ASK107	1000x700x870	102
ASK127	1200x700x870	86
ASK147	1400x700x870	74
ASK167	1600x700x870	65
ASK187	1800x700x870	58
ASK207	2000x700x870	52

800 series

Model	Product Dim(W/D/H mm)	40 HQ Container loading
ASK108	1000x800x870	88
ASK128	1200x800x870	74
ASK148	1400x800x870	64
ASK168	1600x800x870	56
ASK188	1800x800x870	50
ASK208	2000x800x870	45

STAINLESS STEEL WORK CABINET - WITH UPSTAND

- High quality stainless steel
- Height-adjustable shelf
- Single hinged door or 2 sliding doors



ASK66A



ASK126A



ASK166A

600 series

Model	Product Dim(W/D/H mm)	40 HQ Container loading
ASK66A	600x600x870+100	173
ASK86A	800x600x870+100	119
ASK106A	1000x600x870+100	107
ASK126A	1200x600x870+100	89
ASK146A	1400x600x870+100	77
ASK166A	1600x600x870+100	68
ASK186A	1800x600x870+100	60
ASK206A	2000x600x870+100	54

700 series

Model	Product Dim(W/D/H mm)	40 HQ Container loading
ASK67A	600x700x870+100	150
ASK87A	800x700x870+100	103
ASK107A	1000x700x870+100	92
ASK127A	1200x700x870+100	77
ASK147A	1400x700x870+100	67
ASK167A	1600x700x870+100	58
ASK187A	1800x700x870+100	52
ASK207A	2000x700x870+100	47

800 series

Model	Product Dim(W/D/H mm)	40 HQ Container loading
ASK108A	1000x800x870+100	80
ASK128A	1200x800x870+100	67
ASK148A	1400x800x85+100	57
ASK168A	1600x800x870+100	50
ASK188A	1800x800x870+100	44
ASK208A	2000x800x870+100	40

STAINLESS STEEL WORK CABINET - WITH 3 DRAWERS ON THE RIGHT WITHOUT UPSTAND



ASK166R3

- Body, drawers and doors in high quality stainless steel
- Work surface without upstand
- 2 double-walled sliding doors

600 series

Model	Product Dim(W/D/H mm)	40 HQ Container loading
ASK146R3	1400x600x870	86
ASK166R3	1600x600x870	75
ASK186R3	1800x600x870	67
ASK206R3	2000x600x870	60

700 series

Model	Product Dim(W/D/H mm)	40 HQ Container loading
ASK147R3	1400x700x870	74
ASK167R3	1600x700x870	65
ASK187R3	1800x700x870	58
ASK207R3	2000x700x870	52

STAINLESS STEEL WORK CABINET - WITH 3 DRAWERS ON THE RIGHT & UPSTAND



ASK166R3A

- Body, drawers and doors in high quality stainless steel
- Work surface with upstand
- 2 double-walled sliding doors
- Height-adjustable shelf

600 series

Model	Product Dim(W/D/H mm)	40 HQ Container loading
ASK146R3A	1400x600x870+100	77
ASK166R3A	1600x600x870+100	68
ASK186R3A	1800x600x870+100	60
ASK206R3A	2000x600x870+100	54

700 series

Model	Product Dim(W/D/H mm)	40 HQ Container loading
ASK147R3A	1400x700x870+100	67
ASK167R3A	1600x700x870+100	58
ASK187R3A	1800x700x870+100	52
ASK207R3A	2000x700x870+100	47

STAINLESS STEEL WORK CABINET - WITH 3 DRAWERS ON THE LEFT WITHOUT UPSTAND



ASK166L3

- Body, drawers and doors in high quality stainless steel
- Work surface without upstand
- 2 double-walled sliding doors

600 series

Model	Product Dim(W/D/H mm)	40 HQ Container loading
ASK146L3	1400x600x870	86
ASK166L3	1600x600x870	75
ASK186L3	1800x600x870	67
ASK206L3	2000x600x870	60

700 series

Model	Product Dim(W/D/H mm)	40 HQ Container loading
ASK147L3	1400x700x870	74
ASK167L3	1600x700x870	65
ASK187L3	1800x700x870	58
ASK207L3	2000x700x870	52

STAINLESS STEEL FURNITURE

STAINLESS STEEL WORK CABINET - WITH 3 DRAWERS ON THE LEFT & UPSTAND



ASK166L3A

- High quality stainless steel
- Middle shelf height can be adjustable
- The door is double-layered and more stable
- The door pulley sounds small and quiet.
- The door is easy to disassemble
- Height adjustable 870-970mm
- Two choices with and without splash back: with the splash back to prevent water from splashing onto the wall, without the splash back can be spliced together
- Silent pulley for drawers
- Different drawers that can be stored separately

600 series

Model	Product Dim(W/D/H mm)	40 HQ Container loading
ASK146L3A	1400x600x870+100	77
ASK166L3A	1600x600x870+100	68
ASK186L3A	1800x600x870+100	60
ASK206L3A	2000x600x870+100	54

700 series

Model	Product Dim(W/D/H mm)	40 HQ Container loading
ASK147L3A	1400x700x870+100	67
ASK167L3A	1600x700x870+100	58
ASK187L3A	1800x700x870+100	52
ASK207L3A	2000x700x870+100	47

STAINLESS STEEL WORK CABINET WITH HATCH



ADK126



ADK166

- There are doors on both sides, and both sides can be opened.
- Convenient for both sides to operate at the same time.
- Save work time and improve work efficiency.
- Can be placed in the center of the kitchen to save operating space
- Large capacity storage space
- High quality stainless steel
- Middle shelf height can be adjustable
- The door is double-layered and more stable
- The door sounds small and quiet.
- The door is easy to disassemble



ADK206

600 series

Model	Product Dim(W/D/H mm)	40 HQ Container loading
ADK106	1000x600x870	119
ADK126	1200x600x870	99
ADK146	1400x600x870	86
ADK166	1600x600x870	75
ADK186	1800x600x870	67
ADK206	2000x600x870	60

700 series

Model	Product Dim(W/D/H mm)	40 HQ Container loading
ADK107	1000x700x870	102
ADK127	1200x700x870	86
ADK147	1400x700x870	74
ADK167	1600x700x870	65
ADK187	1800x700x870	58
ADK207	2000x700x870	52

BEVERAGE DISPENSER BASE CABINET WITH CUP HOLDERS & ICE TRAY

- Made entirely of high quality stainless steel
- High functionality and stable quality
- Interior with rounded transitions (easier to clean)
- Modern Design
- 3/4 cup dispensers
- 1 ice cube compartment
- Uncooled ice cube compartment with integrated water drain



KBASK120



KBASK150

Model	Product Dim(W/D/H mm)	40 HQ Container loading
KBASK120	1200x800x800	46
KBASK150	1500x800x800	28

SUBSTRUCTURE

- Body made of high quality stainless steel
- Black oxidized stainless steel doors
- The highest standard in processing
- Color of the doors: high-gloss black



GK466T



GK866T



GK126T



GK166T

Model	Product Dim(W/D/H mm)	40 HQ Container loading
GK466T	400x660x587	390
GK866T	800x660x587	210
GK126T	1200x660x587	130
GK166T	1600x660x587	120

- Body and doors in high quality stainless steel
- Can be combined with other products in the series: Mario 700
- Easy to clean



UBK400-E
UBK46-E



UBK800-E
UBK66-E



UBK1200-E
UBK126-E



UBK1600-E
UBK166-E

560 series

Model	Product Dim(W/D/H mm)	40 HQ Container loading
UBK46-E	400x560x587	475
UBK66-E	800x560x587	266
UBK126-E	1200x560x587	140
UBK166-E	1600x560x587	135

660 series

Model	Product Dim(W/D/H mm)	40 HQ Container loading
UBK400-E	400x660x587	390
UBK800-E	800x660x587	210
UBK1200-E	1200x660x587	130
UBK1600-E	1600x660x587	120

STAINLESS STEEL FURNITURE

RUBBISH BIN WITH ROLL CONTAINER

- Rubbish bin (square) with roll container
- Rubbish collecting table with hole dia.210mm
- Insertion opening & front pull-out
- Removable waste bin



MEK77L N



MEK77AL N

Model	Product Dim(W/D/H mm)	40 HQ Container loading
MEK77LN	700x700x870	142
MEK77ALN	700x700x870+100	128

- High quality stainless steel
- Rubbish collecting table without hole
- Removable



MEK77 N



MEK77AN

Model	Product Dim(W/D/H mm)	40 HQ Container loading
MEK77N	700x700x800	142
MEK77AN	700x700x800+100	128

FLOUR TROLLEY

- High quality stainless steel
- With two-part lid
- Splashproof

AEK46
AEK47

Model	Product Dim(W/D/H mm)	40 HQ Container loading
AEK46	400x600x790	332
AEK47	400x700x790	286

LITTER BIN WITH LIFT LID



ABFK100

- Trash can (round)
- High quality stainless steel
- Capacity : 100 liters
- With foot pedal
- Automatically lifting hinged lid



ABFK100D

- Trash can (round)
- High quality stainless steel
- Capacity : 100 liters
- Wheels & Handles
- With lifting lid

Model	Product Dim(W/D/H mm)	40 HQ Container loading
ABFK100	φ=450 460x610x720	180
ABFK50	φ=380 365x540x630	204
ABFK75	φ=450 460x610x610	192

Model	Product Dim(W/D/H mm)	40 HQ Container loading
ABFK100D	φ=450 460x610x720	180
ABFK50D	φ=380 395x540x630	204
ABFK75D	φ=450 465x610x630	192

DRAWER CABINET



SS2K56
SS2K57



SS2K56A
SS2K57A



SS3K56
SS3K57



SS3K56A
SS3K57A

- Body and drawers in high quality stainless steel
- Rounded edges
- Height-adjustable stainless steel feet
- Fits in the drawers: 1/2, 1/4, 2/8, 1/3, 1/6, 1/9 GN containers



SS4K56
SS4K57



SS4K56A
SS4K57A



SS6K106
SS6K107



SS6K106A
SS6K107A

600 series

Model	Product Dim(W/D/H mm)	40 HQ Container loading
SS2K56	500x600x870	228
SS2K56A	500x600x870+100	205
SS3K56	500x600x870	228
SS3K56A	500x600x870+100	205
SS4K56	500x600x870	228
SS4K56A	500x600x870+100	205
SS6K106	1000x600x870	119
SS6K106A	1000x600x870+100	107

700 series

Model	Product Dim(W/D/H mm)	40 HQ Container loading
SS2K57	500x700x870	197
SS2K57A	500x700x870+100	178
SS3K57	500x700x870	197
SS3K57A	500x700x870+100	178
SS4K57	500x700x870	197
SS4K57A	500x700x870+100	178
SS6K107	1000x700x870	102
SS6K107A	1000x700x870+100	92

STAINLESS STEEL FURNITURE

CORNER CABINET

- High quality stainless steel
- Work surface with upstand or without upstand
- 1 hinged door
- Space saving



ESK106
ESK107



ESK106A
ESK107A

600 series

Model	Product Dim(W/D/H mm)	40 HQ Container loading
ESK106	1000x600x870	73
ESK106A	1000x600x870+100	66

700 series

Model	Product Dim(W/D/H mm)	40 HQ Container loading
ESK107	1000x700x870	73
ESK107A	1000x700x870+100	66

CORNER WORK TABLE



ATEK108



ATEK108A

Model	Product Dim(W/D/H mm)	40 HQ Container loading
ATEK106	1000x600+600x1000x870	260
ATEK107	1000x700+700x1000x870	260
ATEK108	1150x800+800x1150x870	210

Model	Product Dim(W/D/H mm)	40 HQ Container loading
ATEK106A	1000x600+600x1000x870+100	200
ATEK107A	1000x700+700x1000x870+100	200
ATEK108A	1150x800+800x1150x870+100	180

TABLEWARE CABINET

- High quality stainless steel
- Middle shelf height can be adjustable
- The door is double-layered and more stable
- The door pulley sounds small and quiet
- The door is easy to disassemble
- Height adjustable



GSK660



GSK1060



GSK1460

600 series

Model	Product Dim(W/D/H mm)	40 HQ Container loading
GSK660	600x600x1800	98
GSK860	800x600x1800	75
GSK1060	1000x600x1800	60
GSK1260	1200x600x1800	50
GSK1460	1400x600x1800	43
GSK1660	1600x600x1800	38

700 series

Model	Product Dim(W/D/H mm)	40 HQ Container loading
GSK670	600x700x1800	85
GSK870	800x700x1800	64
GSK1070	1000x700x1800	52
GSK1270	1200x700x1800	43
GSK1470	1400x700x1800	37
GSK1670	1600x700x1800	33

WALL CABINET

- High quality stainless steel
- Middle shelf height can be adjustable
- Easy to install



WOK104



WOK208



WOK810

650 series

Model	Product Dim(W/D/H mm)	40 HQ Container loading
WOK84	800x400x650	292
WOK104	1000x400x650	236
WOK124	1200x400x650	197
WOK144	1400x400x650	170
WOK164	1600x400x650	149
WOK184	1800x400x650	133
WOK204	2000x400x650	120

800 series

Model	Product Dim(W/D/H mm)	40 HQ Container loading
WOK88	800x400x800	240
WOK108	1000x400x800	193
WOK128	1200x400x800	162
WOK148	1400x400x800	139
WOK168	1600x400x800	122
WOK188	1800x400x800	109
WOK208	2000x400x800	98

1000 series

Model	Product Dim(W/D/H mm)	40 HQ Container loading
WOK810	800x400x1000	193
WOK1010	1000x400x1000	156
WOK1210	1200x400x1000	130
WOK1410	1400x400x1000	112
WOK1610	1600x400x1000	98
WOK1810	1800x400x1000	88
WOK2010	2000x400x1000	79

- High quality stainless steel
- Middle shelf height can be adjustable
- The door is double-layered and more stable
- The door sounds small and quiet.
- The door is easy to disassemble
- Easy to install



WSK64



WSK84



WSK124

650 series

Model	Product Dim(W/D/H mm)	40 HQ Container loading
WSK64	600x400x650	386
WSK84	800x400x650	292
WSK104	1000x400x650	236
WSK124	1200x400x650	197
WSK144	1400x400x650	170
WSK164	1600x400x650	149
WSK184	1800x400x650	133
WSK204	2000x400x650	120

STAINLESS STEEL FURNITURE

WALL CABINET

- High quality stainless steel
- Very high load capacity Hinged or sliding doors available
- Intermediate floor



WSK88



WSK810



WSK1210

800 series

Model	Product Dim(W/D/H mm)	40 HQ Container loading
WSK88	800x400x800	240
WSK108	1000x400x800	193
WSK128	1200x400x800	162
WSK148	1400x400x800	139
WSK168	1600x400x800	122
WSK188	1800x400x800	109
WSK208	2000x400x800	98

1000 series

Model	Product Dim(W/D/H mm)	40 HQ Container loading
WSK810	800x400x1000	193
WSK1010	1000x400x1000	156
WSK1210	1200x400x1000	130
WSK1410	1400x400x1000	112
WSK1610	1600x400x1000	98
WSK1810	1800x400x1000	88
WSK2010	2000x400x1000	79

SELF ASSEMBLY



without sliding door

WOK104Z

- Additional storage space for prep materials
- Open design
- Rounded corners
- Extremely high carrying capacity
- space-saving
- Compact, robust design
- Ground and middle shelf
- High-quality stainless steel



Sliding door enables gently opening and closing

Model	Product Dim(W/D/H mm)	40 HQ Container loading
WOK84Z	800x400x650	475
WOK104Z	1000x400x650	410
WOK124Z	1200x400x650	320
WOK144Z	1400x400x650	310
WOK164Z	1600x400x650	270
WOK184Z	1800x400x650	240
WOK204Z	2000x400x650	220

Model	Product Dim(W/D/H mm)	40 HQ Container loading
WSK64Z	600x400x650	620
WSK84Z	800x400x650	455
WSK104Z	1000x400x650	380
WSK124Z	1200x400x650	335
WSK144Z	1400x400x650	300
WSK164Z	1600x400x650	265
WSK184Z	1800x400x650	235
WSK204Z	2000x400x650	210

SELF ASSEMBLY



ASFK106

- Rounded corners
- Ideal working height
- Extremely high carrying capacity
- Ground and middle shelf
- Doors with soft open/close mechanism
- Body and doors made of premium stainless steel
- Easy to clean
- Easy mounting

600 series

Model	Product Dim(W/D/H mm)	40 HQ Container loading
ASFK106	1000x600x870	287
ASFK126	1200x600x870	244
ASFK146	1400x600x870	213
ASFK166	1600x600x870	188
ASFK186	1800x600x870	169
ASFK206	2000x600x870	153

700 series

Model	Product Dim(W/D/H mm)	40 HQ Container loading
ASFK107	1000x700x870	243
ASFK127	1200x700x870	225
ASFK147	1400x700x870	196
ASFK167	1600x700x870	173
ASFK187	1800x700x870	155
ASFK207	2000x700x870	140



ASFK106A

- Rounded corners
- Ideal working height
- Extremely high carrying capacity
- Ground and middle shelf
- Doors with soft open/close mechanism
- Body and doors made of premium stainless steel
- Easy to clean
- Easy mounting

600 series

Model	Product Dim(W/D/H mm)	40 HQ Container loading
ASFK106A	1000x600x870+100	243
ASFK126A	1200x600x870+100	225
ASFK146A	1400x600x870+100	196
ASFK166A	1600x600x870+100	173
ASFK186A	1800x600x870+100	155
ASFK206A	2000x600x870+100	140

700 series

Model	Product Dim(W/D/H mm)	40 HQ Container loading
ASFK107A	1000x700x870+100	228
ASFK127A	1200x700x870+100	211
ASFK147A	1400x700x870+100	183
ASFK167A	1600x700x870+100	162
ASFK187A	1800x700x870+100	145
ASFK207A	2000x700x870+100	132

STAINLESS STEEL FURNITURE

STAINLESS STEEL CASH DESK



KTK57

- High quality stainless steel cash desk
- Suitable for pizzerias
- Additional storage space for work materials
- Height adjustable feet



KTK57S

open door

Model	Product Dim(W/D/H mm)	40 HQ Container loading
KTK57	500x700x870+150	152
KTK58	500x800x870+150	134

with drawer

Model	Product Dim(W/D/H mm)	40 HQ Container loading
KTK57S	500x700x870+150	152
KTK58S	500x800x870+150	134

WALL-HANGING CABINET WITH 1 LAYER MIDDLE SHELF AND DOORS

- High quality stainless steel
- Height adjustable



EHK165

Model	Product Dim(W/D/H mm)	40 HQ Container loading
EHK165	1000x400x650	92

EXHAUST HOOD NO BLOWER WITH FILTER



WHK107



WHK127



WHK147

Model	Product Dim(W/D/H mm)	40 HQ Container loading
WHK107	1000x450x700	150
WHK127	1200x450x700	130
WHK147	1400x450x700	110

FLAME PROTECTION FILTER

- High quality stainless steel
- Temperature resistant, long lifetime
- Reliable prevention of flame propagation
- Efficient removal of grease vapor
- Suitable for kitchen areas with food serving, food storage, scullery



FSK5050

Model	Product Dim(W/D/H mm)	40 HQ Container loading
FSK4040	400x400x20	8910
FSK4050	400x500x20	8910
FSK5050	500x500x20	8910

FOOD SHELF

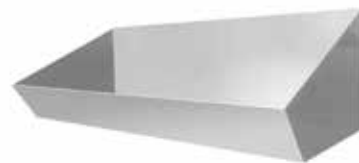

AUWK120

Model	Product Dim(W/D/H mm)	40 HQ Container loading
AUWK100	1000x385x260	572
AUWK120	1200x385x260	478
AUWK80	800x385x260	678

WALL SHELVES

- High quality stainless steel
- Easy to assemble
- Can be added layers to make more layers
- Height adjustable
- Strong bearing capacity



WBK183

300 series

Model	Product Dim(W/D/H mm)	40 HQ Container loading
WBK63	600x300x660	3227
WBK83	800x300x660	2448
WBK103	1000x300x660	1972
WBK123	1200x300x660	1651
WBK143	1400x300x660	1420
WBK153	1500x300x660	1315
WBK163	1600x300x660	1246
WBK183	1800x300x660	1109
WBK203	2000x300x660	1000

400 series

Model	Product Dim(W/D/H mm)	40 HQ Container loading
WBK64	600x400x660	2448
WBK84	800x400x660	1868
WBK104	1000x400x660	1511
WBK124	1200x400x660	1268
WBK144	1400x400x660	1076
WBK154	1500x400x660	1014
WBK164	1600x400x660	947
WBK184	1800x400x660	845
WBK204	2000x400x660	763

STAINLESS STEEL FURNITURE

STAINLESS STEEL SHELF - WITH 4 SHELVES(ADJUSTABLE)

- Completely made of high quality stainless steel
- Round stainless steel legs, screw connection guarantees high stability
- 4 smooth shelves, max. load per shelf: 80 kg
- Suitable for laboratories & clean rooms, storage rooms & dry storage, hospitals or for private use, cold rooms (up to -80 °C) and canteen kitchens etc.



Model	Product Dim(W/D/H mm)	40 HQ Container loading
ERP105N	1000x500x1800	440
ERP125N	1200x500x1800	370
ERP145N	1400x500x1800	320
ERP165N	1600x500x1800	280
ERP185N	1800x500x1800	250
ERP205N	2000x500x1800	220

SINGLE ADDITIONAL SHELF



Model	Product Dim(W/D mm)
ERP105-1	1000x500
ERP125-1	1200x500
ERP145-1	1400x500
ERP165-1	1600x500
ERP185-1	1800x500
ERP205-1	2000x500

SERVING TROLLEY

- High quality stainless steel
- Facilitates the transport of drinks, food and crockery
- Wheels can be locked for a secure stand
- Max. load: 40kg (per shelf)



S2K105



S3K105

500 series

Model	Product Dim(W/D/H mm)	40 HQ Container loading
S2K85	800x500x940	922
S2K105	1000x500x940	747
S3K85	800x500x940	703
S3K105	1000x500x940	573

600 series

Model	Product Dim(W/D/H mm)	40 HQ Container loading
S2K106	1000x600x940	640
S2K126	1200x600x940	534
S3K106	1000x600x940	486
S3K126	1200x600x940	408

FOLDABLE SERVING TROLLEY

- Save the time and convenient to use, no need to assemble
- Save the space after used and folded
- Convenient to carry on the car for outdoors
- Durable design on the trolley: 50kgs/ layer max.loading capacity when transportation



SWH83

SWKH83

SWH63

Model	Product Dim(W/D/H mm)	40 HQ Container loading
SWH83	880x500x930	320
SWKH83	930x510x930	260
SWH63	635x402x910	412

PLASTIC SERVING TROLLEY

- Good quality of PP material with strong toughness, not easy to damage even if it is stepped on or thrown at high altitude
- Matte surface, wear-resistant and non-slip



SWKH13

SWKH12

Model	Product Dim(W/D/H mm)	40 HQ Container loading
SWKH13	1020x490x980	540
SWKH12	1020x490x980	840

TROLLEY WITH UNDER SHELF

- Serving trolley with 2 shelves
- High quality stainless steel
- For 2 x 12 x GN 1/6 containers
- 4 castors, 2 of which have brakes



SWH16

Model	Product Dim(W/D/H mm)	40 HQ Container loading
SWH16	798x520x940	920

5 SHELVES SERVING TROLLEY

- Less transportation noise
- Good loading capacity
- More display space for 5 layer trolley, sometime can work as a storage rack when lock the wheel



SWH85N

Model	Product Dim(W/D/H mm)	40 HQ Container loading
SWH85N	845x525x1550	570

STAINLESS STEEL FURNITURE

CLEANING TROLLEY

- With 3 shelves & 2 buckets
- Facilitates the transport of detergents, rubbish, etc.
- 4 wheels with parking brake, can be locked for a secure stand



GRWH5#AERWH5

Model	Product Dim(W/D/H mm)	40 HQ Container loading
GRWH5	850x455x935	660
AERWH5	535x380x150 /280x200x300	1080

TRANSPORT TROLLEY

- Convenient to use in foldable design and no need to assemble
- Facilitates the transport of drinks, food and crockery
- Low platform trolley, 1 shelf
- Easy rolling, with 2 fixed and 2 swivel castors



TWH81

Model	Product Dim(W/D/H mm)	40 HQ Container loading
TWH81	820x515x935	800

- Convenient to use in foldable design and no need to assemble
- Max. loading capacity:150kgs
- With 4 pcs of anti-slip rubber particles on the top



TWH71

Model	Product Dim(W/D/H mm)	40 HQ Container loading
TWH71	730 x 480 x 820	1000

INGREDIENT TROLLEY

- High quality stainless steel
- With two-part lid
- With wheels for high mobility



MWH50

Model	Product Dim(W/D/H mm)	40 HQ Container loading
MWH50	590x670x575	240

LAUNDRY TROLLEY

- Ideal for transporting laundry and textiles
- Equipped with 4 wheels
- Laundry bag made of high quality fabric
- Easy to use



WWH9

Model	Product Dim(W/D/H mm)	40 HQ Container loading
WWH9	910x560x920	580

TRAY TROLLEY

- Double tray trolley
- Made of high quality stainless steel
- Perfect for restaurants and hotels
- For 16x GN 1/1
- 4 wheels with 2 brakes
- Easy to use
- Easy to clean
- low noise
- High stability
- Very resistant and durable
- Flexible

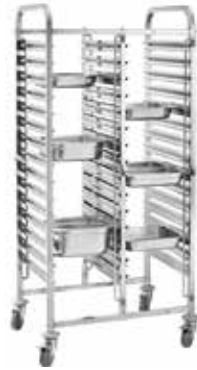

TWDH1611

- For 6x GN 1/1
- 4 wheels with 2 brakes
- High stability



TWH611

Model	Product Dim(W/D/H mm)	40 HQ Container loading
TWDH1611	740x550x1700	450
TWH611	380x550x950	1000



- Square legs for added strength
- Supplied flat packed with easy assembly
- Back support to stop tray sliding all the way through
- Suitable for 1/1, 1/2, 1/3 and 2/3 GN pans

TWH1611N



- Made from stainless steel
- Space for up to 16 trays Ideal for use in bakeries, restaurants, hotels and self-service outlets
- Suitable for GN 2/1, 1/1 trays

TWH1621N



- Quick and easy to assemble
- Equipped with casters, of which two have brakes
- Suitable for use with 60x40cm bakery pan

TWH1564N



- Made from stainless steel and very easy to assemble.
- 16 shelves available
- Suitable for Bakerynorm trays of 60 x 40cm and 1/1, 1/2, 1/3 and 2/3 GN pans

TWH1811N

Model	Product Dim(W/D/H mm)	40 HQ Container loading
TWH1611N	380x550x1700	627
TWH1621N	590x670x1700	554
TWH1564N	470x620x1700	484
TWH1811N	470x620x1735	421

- Tray trolley closed
- Perfect for restaurants and hotels
- 4Castors with 2 brakes
- Easy to operate
- Easy to clean
- Made of high quality stainless steel
- Extremely quiet
- High stability
- Very resistant and durable



TWK1411



TWK1464

Model	Product Dim(W/D/H mm)	40 HQ Container loading
TWK1411	460x640x1800	280
TWK1464	460x640x1800	280

STAINLESS STEEL FURNITURE

STAINLESS STEEL DISH RACK TROLLEY

- High quality stainless steel dish rack trolley for 4/6/7 baskets
- For baskets measuring: 40x40, 40x50 & 50x50 cm, as per different trolleys
- Easy rolling, 2 fixed and 2 swivel castors
- No sharp edges

GKWH45
GKWH44GKWH75
GKWH74

GKWH65

Model	Product Dim(W/D/H mm)	40 HQ Container loading
GKWH45	505x550x1000	1000
GKWH44	455x400x1000	1000
GKWH75	505x550x1710	600
GKWH74	455x400x1710	696
GKWH65	505x550x1700	600

PLATE STACKER

- Double plate stacker, made of high quality stainless steel
- Perfect for eg restaurants and hotels
- For up to 80 plates - Ø 23 - 30cm
- Very resistant and durable

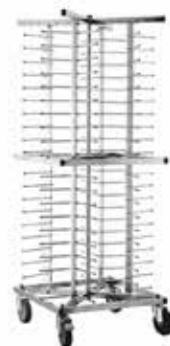

TSDH80

Model	Product Dim(W/D/H mm)	40 HQ Container loading
TSDH80	606x598x1635	382

STAINLESS STEEL FOLDABLE WORK TABLE

- Body made of high quality stainless steel
- Save the time and convenient to use in foldable design and no need to install
- On the top board with wooden board inside, which makes the table much stronger
- Work surface without upstand, square profile table legs
- Very high load capacity, space-saving as it can also be folded



ATH146

Model	Product Dim(W/D/H mm)	40 HQ Container loading
ATH106	1000x600x910	656
ATH126	1200x600x910	600
ATH146	1400x600x910	475
ATH166	1600x600x910	418
ATH186	1800x600x910	373
ATH206	2000x600x910	336

BAGUETTE TRAY

- Made of high quality aluminum, with 5 holes
- Suitable for bakeries, easily removable
- Easy to clean



BABH46



BABH546

Model	Product Dim(W/D/H mm)	40 HQ Container loading
BABH46	600x400x30	7200
BABH546	600x400x30	7200

STAINLESS STEEL CUTLERY TRAY



BEBH13



BEBH14



BEBH15



BEBH24



BEBH36



BEBH36T

- Made of high-quality stainless steel
- Particularly suitable for canteens, snack bars, catering services and buffets
- Compact & space-saving, particularly hygienic, easy to clean

Model	Product Dim(W/D/H mm)	40 HQ Container loading
BEBH13	385x150x180	3960
BEBH14	505x150x180	2640
BEBH15	630x150x180	2640
BEBH24	265x305x200	2400
BEBH36	385x305x200	1800
BEBH36T	385x305x200	1800

WALL SHELF FOR DISHWASHING BASKETS

- High quality stainless steel
- Loading capacity: 50 kg
- Compact & robust design
- Easy to clean, temperature resistant
- Durable, space saving



WBSH55925

Model	Product Dim(W/D/H mm)	40 HQ Container loading
WBSH55925	559x457x286	5584
WBSH10625	1067x457x286	3066
WBSH15725	1575x457x286	2107
WBSH15025	1505x457x286	2201
WBSH20025	2005x457x286	1667
WBSH25025	2505x457x286	1341

Model	Product Dim(W/D/H mm)	40 HQ Container loading
WBSH55932	559x457x286	5584
WBSH10632	1067x457x286	3066
WBSH15732	1575x457x286	2107
WBSH15032	1505x457x286	2201
WBSH20032	2005x457x286	1667
WBSH25032	2505x457x286	1341

STAINLESS STEEL FURNITURE

SPICE SHELF



GAH316



GAH416



GAH516



GAH616

Model	Product Dim(W/D/H mm)	40 HQ Container loading
GAH316	515x250x210	1600
GAH416	690x250x210	1320
GAH516	825x250x210	1060
GAH616	990x250x210	800

- High quality stainless steel
- Welding style, much stronger
- Easy to operate
- Easy to clean



GABK100



GABK120



GABK160



GABK180

Model	Product Dim(W/D/H mm)	40 HQ Container loading
GABK100	1000x310x220	490
GABK120	1200x310x220	413
GABK160	1600x310x220	313
GABK180	1800x310x220	280

- High quality stainless steel
- Welding style, much stronger
- With cover, is cleaner



GAK414



GAK614



GAK814



GAK1014

Model	Product Dim(W/D/H mm)	40 HQ Container loading
GAK414	800x311x264	530
GAK614	1200x311x264	360
GAK814	1600x311x264	274
GAK1014	2000x311x264	253

CUP DISPENSER



BESGH2



BESGH3



BESGH4

Model	Product Dim(W/D/H mm)	40 HQ Container loading
BESGH2	280x150x680	1160
BESGH3	460x150x680	800
BESGH4	580x150x680	680

BUILT-IN CUP DISPENSER



EBESH80



EBESH90



EBESH100

Model	Product Dim(W/D/H mm)	40 HQ Container loading
EBESH80	80x115x 640	3200
EBESH90	90x115x640	3200
EBESH100	100x115x 640	3200

S/S PET GROOMING BATHTUB

- High quality stainless steel
- Professional stainless steel pet grooming tub for grooming your pet
- Eliminate unpleasant odors and dirt in your premises with our pet care tub
- The mobile shower head allows you to easily clean your pet
- Excellent sealing performance eliminates water leakage
- The non-slip grooved surface on the stairs helps your pet to get in or out safely
- Storage grid for care products
- Pilot holes for hot and cold water connection



HTPWEL



HTPW



HTPWEV

Model	Product Dim(W/D/H mm)	40 HQ Container loading
HTPWEL	1240x556x1420	94
HTPW	850x480x1076	309
HTPWEV	870x490x1020	240

COFFEE GROUNDS DRAWER

- High quality stainless steel
- Height adjustable feet
- Easy to clean



KSK1041



KSK541

Model	Product Dim(W/D/H mm)	40 HQ Container loading
KSK541	410x510x115	2367
KSK1041	820x510x115	1224

STAINLESS STEEL FURNITURE

INSECT KILLER



IVG40

- Special UV-A tube with spectrum at 365mm as the best luring efficiency to the flying insects.
- Average working life of the tube: 8000 hours
- Special treated Aluminium Alloy material for no scratch,oil proof
- ABS fire-resistant plastic material of the side board.
- With chain holder at the top cover for easy hanging.
- Full protected outer mesh for high safety using.
- Removable collection tray for easy cleaning.
- Non-toxic, no spray, eco-friendly, and easy to use.
- Ideal for using at commercial areas, such as restaurants, canteens,offices, supermarkets ,etc.

Model	Product Dim(W/D/H mm)	40 HQ Container loading
IVG16	330x100x263	5862
IVG20	380x100x263	5100
IVG40	635x100x311	2693

STAINLESS STEEL GN CONTAINER



- High quality stainless steel
- Stable and scratch-resistant
- Easy to use
- Easy to clean



GDY11



GBY1140



GBY11150



GDY11L



GBY1140G



GBY11150G

GN 1/1

Model	Product Dim(W/D/H mm)	40 HQ Container loading
GDY11	530x325	970
GBY1120	530x325x20	5680
GBY1140	530x325x40	3220
GBY1165	530x325x65	2160
GBY11100	530x325x100	1410
GBY11150	530x325x150	1120
GBY11200	530x325x200	1050

GN 1/1

Model	Product Dim(W/D/H mm)	40 HQ Container loading
GDY11L	530x325	970
GBY1120G	530x325x20	5680
GBY1140G	530x325x40	3220
GBY1165G	530x325x65	2160
GBY11100G	530x325x100	1410
GBY11150G	530x325x150	1120
GBY11200G	530x325x200	1050

STAINLESS STEEL GN CONTAINER



GDY12

GBY1240

GBY12150



GDY12L

GBY1220 G

GBY12100G

GTY1210

GN 1/2

Model	Product Dim(W/D/H mm)	40 HQ Container loading
GDY12	325x265	2240
GBY1220	325x265x20	3666
GBY1240	325x265x40	5300
GBY1265	325x265x65	3400
GBY12100	325x265x100	1930
GBY12150	325x265x150	1850
GBY12200	325x265x200	1550
GTY1210	325x265x10	1000

GN 1/2

Model	Product Dim(W/D/H mm)	40 HQ Container loading
GDY12L	325x265	2240
GBY1220G	325x265x20	3666
GBY12100G	325x265x100	1930
GBY12200G	325x265x200	1550



GDY13

GBY1340

GBY13150



GDY13L

GBY13150G

GN 1/3

Model	Product Dim(W/D/H mm)	40 HQ Container loading
GDY13	325x176	1560
GBY1320	325x176x20	3666
GBY1340	325x176x40	7130
GBY1365	325x176x65	3800
GBY13100	325x176x100	2350
GBY13150	325x176x150	2120
GBY13200	325x176x200	1940

GN 1/3

Model	Product Dim(W/D/H mm)	40 HQ Container loading
GDY13L	325x176	1560
GBY13100G	325x176x100	2350
GBY13150G	325x176x150	2120
GBY13200G	325x176x200	1940

STAINLESS STEEL FURNITURE

STAINLESS STEEL GN CONTAINER



GDY14



GBY1465



GBY14200



GDY14L



GBY1665



GBY16150



GDY16



GDY16L

GN 1/4

Model	Product Dim(W/D/H mm)	40 HQ Container loading
GDY14	265x162	4090
GDY14L	265x162	4090
GBY1440	265x162x40	2400
GBY1465	265x162x65	4960
GBY14100	265x162x100	3110
GBY14150	265x162x150	2790
GBY14200	265x162x200	720

GN 1/6

Model	Product Dim(W/D/H mm)	40 HQ Container loading
GDY16	176x162	1680
GBY1665	176x162x65	7400
GBY16100	176x162x100	4950
GBY16150	176x162x150	4020
GBY16200	176x162x200	3517
GDY16L	176x162	1680



GDY19



GBY19100



GDY19L



GBY2140



GBY21150



GBY21100G



GBY2120G

GN 1/9

Model	Product Dim(W/D/H mm)	40 HQ Container loading
GDY19	176x108	8640
GBY1965	176x108x65	10280
GBY19100	176x108x100	6540
GDY19L	176x108	8640

GN 2/1

Model	Product Dim(W/D/H mm)	40 HQ Container loading
GBY2140	650x530x40	1510
GBY2165	650x530x65	756
GBY21150	650x530x150	492
GBY21200	650x530x200	420
GBY2120G	650x530x20	1692
GBY21100G	650x530x100	612
GBY21150G	650x530x150	492

STAINLESS STEEL GN CONTAINER



GDY23



GBY2340



GDY24



GBY2440



GBY23100



GDY23L



GBY24150

GN 2/3

Model	Product Dim(W/D/H mm)	40 HQ Container loading
GDY23	353x325	1710
GBY2320	353x325x20	3142
GBY2340	353x325x40	1953
GBY2365	353x325x65	1900
GBY23100	353x325x100	1420
GBY23150	353x325x150	1330
GBY23200	353x325x200	558
GDY23L	353x325	1710

GN 2/4

Model	Product Dim(W/D/H mm)	40 HQ Container loading
GDY24	530x162	1638
GBY2440	530x162x40	2394
GBY2465	530x162x65	1134
GBY24100	530x162x100	1008
GBY24150	530x162x150	882

MILK JUG WITH LID

- Food grade stainless steel, anti-rust and anti-corrosion
- The lid with a rubber seal and a latch ensures a secure closure
- Practical carrying handles for easy transport
- Ideal for milk, food, etc. Suitable for transport and storage
- Stable construction
- Widely used in various applications: using in farms, pastures, dairy plants, etc
- Easy to clean up: Clean with detergent and wipe dry



MKX25
MKX40

Model	"Product Dim (W/D/H mm)"	Net Volume(L)	40 HQ Container loading
MKX25	320x200x420	25	1295
MKX40	380x250x470	40	804

STAINLESS STEEL FURNITURE

ALUMINUM PIZZA PEEL

- For pizza ovens
- Made of high quality aluminum
- Shovel for placing and removing pizzas from the pizza oven
- Extra light quality for better handling
- Heat resistance
- Easy handling
- Easy to clean



PSAJ28



PSAJ2317



PSAJ301



PSAJ3590



PSAJ337



PSAJ215



PSAJ3317

Model	Product Dim(W/D/H mm)	40 HQ Container loading
PSAJ28	228x228x800	2625
PSAJ2317	230x230x1700	1750
PSAJ301	300x300x1100	1750
PSAJ3590	305x355x905	1875
PSAJ337	310x350x660	1800
PSAJ215	170x240x510	3500
PSAJ3317	405x455x1730	1296

SINK TAP

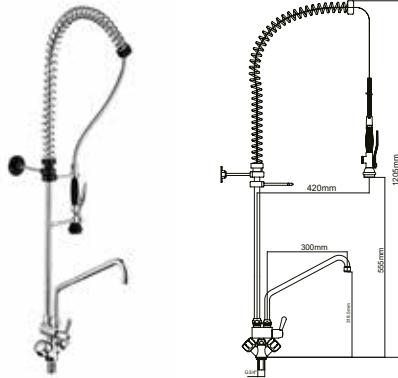

- One-hole dish spray
- 2 mixing valves
- With swivel spout
- Shower can be swiveled by 360°
- Stable and flexible spring

Model	Product Dim(W/D/H mm)	40 HQ Container loading
GY2	21 x 430 x 1205	3500

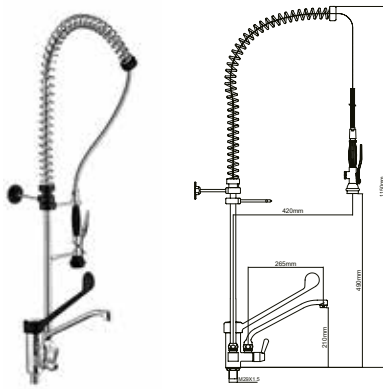

- One-hole dish spray
- Swivel tap & single lever mixer
- For wall mounting
- Shower can be swiveled by 360°

Model	Product Dim(W/D/H mm)	40 HQ Container loading
GY3	21 x 420 x 1150	1400

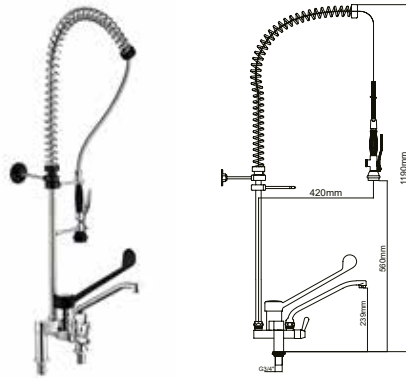

- Two-hole dish shower
- Swivel tap & single lever mixer
- For wall mounting
- Shower can be swiveled by 360°
- Very resistant and durable

Model	Product Dim(W/D/H mm)	40 HQ Container loading
GY4	21 x 420 x 1190	1400

STAINLESS STEEL FURNITURE

SINK TAP

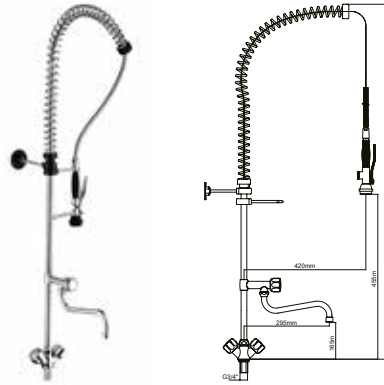

- One-hole dish spray
- 2 mixing valves
- With swivel spout on the standpipe
- Shower can be swiveled by 360°

Model	Product Dim(W/D/H mm)	40 HQ Container loading
-------	-----------------------	-------------------------

GY6	21 x 420 x 1115	1750
-----	-----------------	------

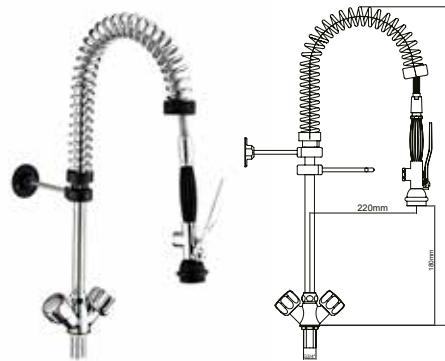

- One-hole dish spray
- Shower can be swiveled by 360°
- For wall mounting
- 2 mixing valves

Model	Product Dim(W/D/H mm)	40 HQ Container loading
-------	-----------------------	-------------------------

GY7	21 x 220 x 565	1750
-----	----------------	------

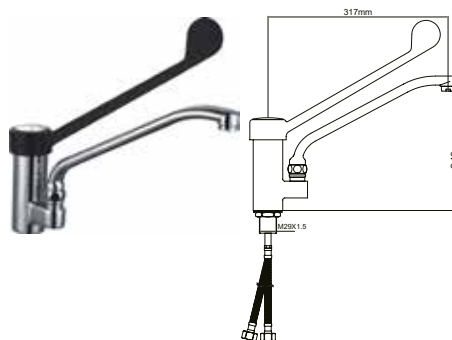

- Single hole mixer tap
- Swivel tap & single lever mixer
- Extra long faucet
- Solid plastic head and lever

Model	Product Dim(W/D/H mm)	40 HQ Container loading
-------	-----------------------	-------------------------

MY3	307 x 50 x 250	6656
-----	----------------	------

SINK TAP

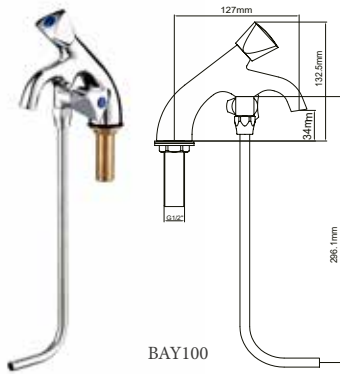

BAY100

- Single hole mixer tap
- Device for table mounting
- One-hole battery with 1 flushing pipe
- Suitable for: 1 sink

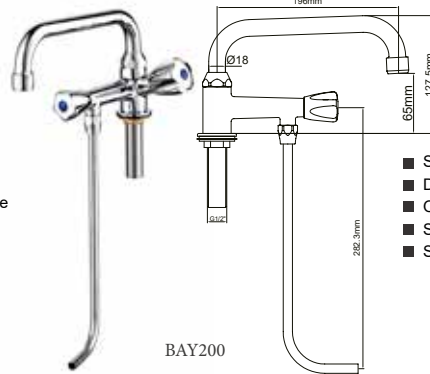

BAY200

- Single hole mixer tap
- Device for table mounting
- One-hole battery with 1 flushing pipe
- Swivel tap 360°
- Suitable for: 1 sink

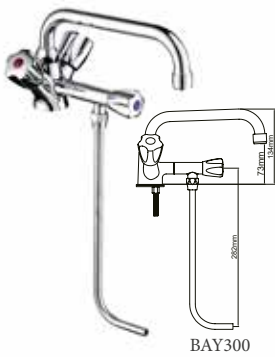

BAY300

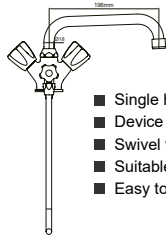

- Single hole mixer tap
- Device for table mounting
- Swivel tap 360°
- Suitable for: 1 sink
- Easy to clean

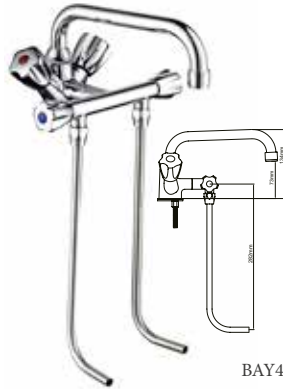

BAY400

- Single hole mixer tap
- Device for table mounting
- Swivel tap 360°
- Suitable for: 2 sinks

Model	Product Dim(W/D/H mm)	40 HQ Container loading
BAY100	34 x 127 x 460	6656
BAY200	65 x 196 x 460	6656
BAY300	73 x 196 x 460	6656
BAY400	73 x 196 x 460	6656